

NOTICE! No mixing valve will work satisfactorily if improperly installed. We suggest, therefore, that you read these instructions carefully before installing and follow directions as outlined. Handle the mixing valve with care.

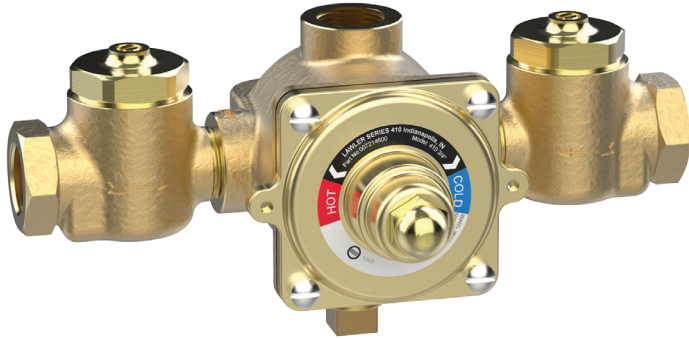

Model 410 Thermostatic Mixing Valve

CAPACITIES – MODEL 410

Pressure Drop PSI	5	10	20	30	45	60
Valve Number	Capacity					
410-GPM	5	8	12	15	20	24
410-LPM	19	30	45	56	75	91

1/4 gpm when properly installed in recirculated system.
The minimum flow of the Series 410 is 1 GPM.

CAUTION: When maintaining and adjusting the mixing valve, all fixtures should be isolated from use. Lawler Manufacturing Co., Inc. recommends that you work safely at all times and in a manner consistent with the OSHA Lock/Tagout standard, 29 CFR 1910.147 and other applicable standards.

This installation & maintenance manual covers all configurations of the Model 410.

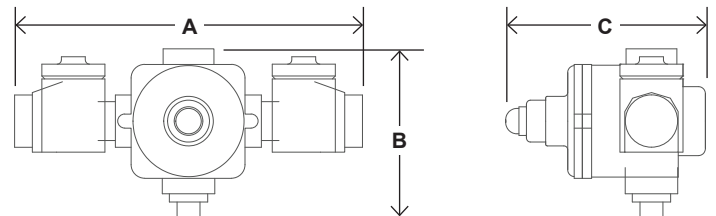

DIMENSIONS

Valve Number	A	B	C
410	9-1/2"	4-1/2"	5-1/2"

Dimensions are for reference purposes only. For rough-in dimensions please refer to Lawler's Revit/BIM models found at temperedwater.com.

Inlets & outlet are 3/4" NPT.

Mixing valve

Valve is carefully assembled and tested at the factory and set to deliver water at any temperature between full cold and 115°F. Failure of the cold water supply will cause the hot water seat to close. The label on the valve cover is marked "WARMER - COOLER," so that the temperature set screw can be set accordingly.

Stop and Check Valves

Each inlet of the mixing valve must have a screwdriver-operated check valve. Both the cold and hot water stop and check valves must be open at all times for proper functioning of the valve.

The stop and check valves serve two purposes:

1. They prevent the hot or cold water from by-passing through the mixing valve.
2. They provide convenient means to shut the supplies to the mixer for cleaning or repairs.

Stop and checks are required whenever downstream shut off devices are used.

Temperature Adjustment

The temperature of the hot water supplying the mixing valve should be at least 20 degrees higher than maximum required valve setting. Valves are normally set at factory for 115°F maximum outlet temperature with 140°F inlet. If readjustment is required, proceed as follows:

1. Remove outside acorn nut #2.
2. With narrow blade screwdriver, turn adjusting set screw #5 clockwise to reduce the outlet temperature and counterclockwise to increase outlet temperature. The set screw should not be turned more than 1/2 turn at a time without testing water temperature.
3. When temperature is correct, replace acorn nut.

Adjusting screw #5 may not be turned counter-clockwise more than 1-1/2 turns.

CAUTION: It is not recommended to set maximum outlet temperature above the applicable plumbing code.

Piping Instructions

Before installing the mixer, blow out all pipe lines to be sure that no dirt, such as pipe chips, wicking or lead, can enter the mixing valve. Valve inlets are marked hot and cold. Piping must go to proper inlets.

Maintenance

The Lawler thermostatic mixer should be checked periodically for proper operation and cleaning. See "INSPECTION AND CLEANING VALVE." To test mixing valve for proper setting and operation—proceed as follows:

Checking Mixing Valve

1. CHECKING COLD WATER SHUT-OFF. Shut off hot supply keeping cold supply open. At first, full volume of cold water should pass through valve. The volume of cold water should then be reduced to a very small flow.

Failure of this to occur would indicate:

- a. Piston #15 is stuck in one position. Unit has to be cleaned.
 - b. Valve spring #18 has lost its strength and must be replaced.
 - c. Cold water is in excess of 80°F.
2. CHECKING HOT WATER SHUT-OFF. Open both the hot and cold supplies to mixing valve. Water should flow through valve at 115°F. If not, adjust valve as explained under "TEMPERATURE ADJUSTMENT."

Now shut off the cold water supply to the mixing valve. A properly operating mixer will shut off the hot water almost instantly with hot water temperature supplying the mixing valve at least 15 degrees higher than maximum setting.

Failure to do so would indicate:

- a. Dirt between the hot seat #17 in liner #21 and piston #15 prevents it from closing. Unit has to be cleaned.
- b. The piston #15 could be stuck so that it cannot move because of scale or some other deposit in water. Unit has to be cleaned.
- c. The thermostat has lost its power and has to be replaced with a new one.

Inspection and Cleaning Valve

Shut off hot and cold water supply to mixing valve. Remove body screws #9. Take the cover #26 off valve body. The thermostat, piston and liner can now be examined.

Checking the Thermostat

If cold seat #11 on thermostat is worn or deeply indented, remove it and replace with a new one. If there is a question as to the thermostat being good, hold thermostat under cold water faucet and insert an eraser-capped pencil into the center of thermostat. Make a reference mark where pencil protrudes from the thermostat. Now place the entire thermostat into hot water, approximately 140°F for about one minute. Remove thermostat from water, examine the reference mark on pencil again. At this temperature, it should extend out from former position about 1/8". If it does not, a new thermostat should be installed.

CAUTION: Extreme care should be exercised when placing thermostat in and out of hot water.

Checking Piston and Liner

Remove piston assembly #15 from valve. Check the piston assembly and liner #21 for cleanliness and excessive wear. Check hot disc #17 for wear. Replace all worn parts.

Liner #21 can be removed with a 1-5/8" socket wrench.

Before reassembling the valve, thoroughly flush out with water.

Piston Sub-assembly, consisting of parts #'s 15, 17 and 18, is factory pre-set with Liner #21, as a single unit.

Use only genuine factory parts for replacement of seat washers; thickness will affect the operation of the mixing valve.

When in Need of Information

When writing the factory or one of its representatives in regard to a mixing valve, be sure to give the valve number and serial number appearing on round label plate fastened to the top of the valve.

Repair Kit

Valves can be completely rebuilt in a matter of minutes without removal from the line by installing a repair kit.

WARNING: This product contains chemicals known to the State of California to cause cancer and birth defects or other reproductive harm.

(Installer: California law requires that this warning be given to the consumer.)

For more information: www.oehha.org/prop65

Thermostatic Mixing Valve Cut-away

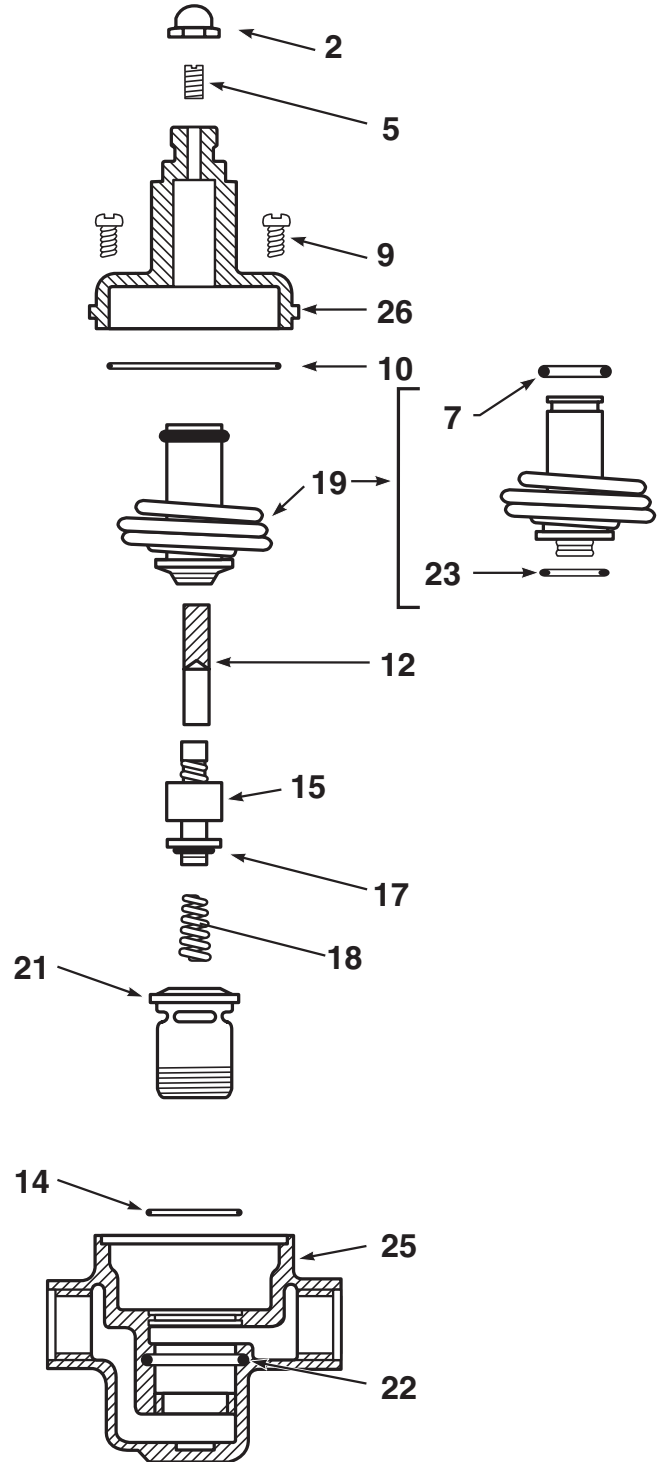

Repair Kits and Assemblies

Item	Description	Contains	Part No.
A	Piston/Liner Kit	18-B-D	79865-00
B	O-Ring & Gasket Kit	7-10-14-22-23	79962-00
C	Cover & Spindle Assembly	2-5-10-26	79271-01
D	Piston & Liner Assembly	14-15-17-21	72014-05
E	Thermostat Assembly	19-10	71036-21

Must specify capacity and finish of valve. Parts shown are for 15-20 GPM. All parts shown are for Plain Bronze finish.

For complete repair kit, order universal kit 79851-00

Repair Kits for Inlet Stop & Checks

NOTE:* Components are not included in repair kit.

3/4" Stop & Check

Part No. 71182-14
Repair Kit 79982-00

Item	Description
1	Adjustment Stem
2	O-ring
*3	Bonnet
4	Spring
5	O-ring
6	Disc Holder
7	O-ring
*8	Body

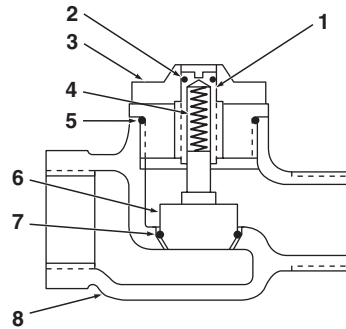

GUARANTEE

We guarantee the Lawler Mixing Valve to be free from defects in workmanship and material, and for a period of one year from date of purchase, will replace any parts found by us to be defective. We will not be held responsible, however, for any labor incidental to, or for any damages caused by defective material. Each mixing valve is thoroughly inspected and tested under actual conditions at our factory.