

NOTICE! No mixing valve will work satisfactorily if improperly installed. We suggest, therefore, that you read these instructions carefully before installing and follow directions as outlined. Handle the mixing valve with care.

The Lawler Series 67 Water Temperature Controller has been carefully assembled and tested at the factory and set to deliver water at any temperature within the control range stamped on the label. At each inlet of the controller is a union angle combination stop and check valve with strainer which should be turned open in operation.

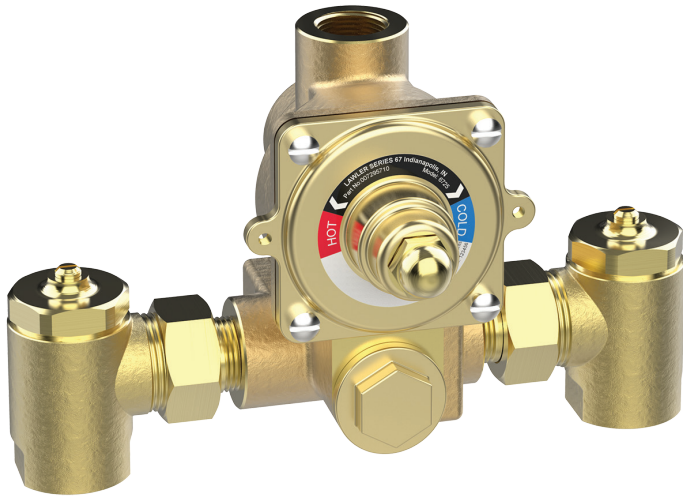

Series 67 Combination Thermostatic and Pressure Balanced Water Controller

CAPACITIES – GPM SERIES 67

Pressure Drop PSI	5	10	20	30	45	60	80
Valve Number	Capacity – GPM						
67-10	2.5	3.5	5.5	8	10	12	14
67-25	6	10	14	18	25	30	34

1/4 gpm when properly installed in recirculated system.

CAPACITIES – LPM SERIES 67

Pressure Drop PSI	5	10	20	30	45	60	80
Valve Number	Capacity – LPM						
67-10	9.4	13.2	22.8	30.3	37.8	45.4	53
67-25	22.7	37.8	53	68	94.6	113	128

Minimum flow for 67-10 is 1/2 Gallon Per Minute
Minimum flow for 67-25 is 1 Gallon Per Minute

CAUTION: When maintaining and adjusting the mixing valve, all fixtures should be isolated from use. Lawler Manufacturing Co., Inc. recommends that you work safely at all times and in a manner consistent with the OSHA Lock/Tagout standard, 29 CFR 1910.147 and other applicable standards.

This installation & maintenance manual covers all configurations of the Series 67.

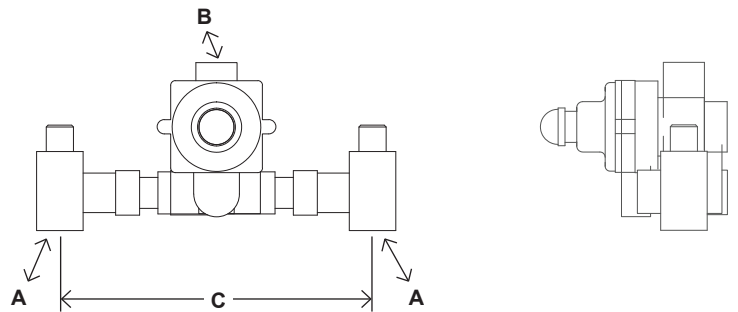

DIMENSIONS

Valve Number	A	N.P.T.	B	N.P.T.	C
67-10	1/2"		1/2"		8"
67-25	3/4"		3/4"		8-3/8"

Dimensions are for reference purposes only. For rough-in dimensions please refer to Lawler's Revit/BIM models found at temperedwater.com.

Performance

The Series 67 will maintain outlet temperature to within 1-1/2°F. under any of the following conditions, providing the recommended minimum flow and minimum supply temperature differentials are not exceeded:

- reduction to minimum flow (1 or 1/2 GPM)
- 30°F change in hot water temperature
- 30°F change in cold water temperature
- 50% drop in inlet supply pressure

Maximum Inlet Conditions

Pressure: 125 psig

Temperature: 200°F

Recommended Conditions

Minimum Flow

1 Gallon Per Minute for 67-25
1/2 Gallon Per Minute for 67-10

Minimum Temperature Differential

Hot and cold water inlets must have a minimum 20°F differential from the outlet set temperature.

Three-Way Protection

Three-Way protection is provided with Lawler's patented backseat.

1. Thermostat Protection.
Lawler's exclusive design cuts water flow if the thermostat's liquid motor fails.
2. Hot Supply Protection.
Responds automatically if the hot water supply is interrupted, or temperature changes.
3. Cold Supply Protection.
Guards against scalding if the cold supply is interrupted.

Lawler Thermostatic Valves adjust for changes in both input temperature and pressure, maintaining constant output.

Operating Principle

Cold: With the stop valves open and adjustment handle in the cold position, the plunger is positioned in the liner so that the hot ports are closed and the cold ports are open, allowing only cold water to pass through the controller.

Warm: When the adjustment handle is moved toward the warm position, the spring forces the piston upward, opening the hot water ports and closing the cold water ports. As the warm water flows over the thermostatic element, which is solidly filled with a thermo-sensitive liquid, the liquid changes in temperature. This change in temperature causes an expansion or contraction of the liquid, resulting in a movement of the flexible bellows. This movement is transferred to the pushrod which in turn moves the piston. This moving action proportions the amount of hot and cold water allowed to enter the mixing valve in accordance with the adjustment handle setting.

Maintenance

The Lawler thermostatic water controller, if correctly installed and properly used, should require very little attention or maintenance. However, every mechanical device, including water controllers, deserves some care. Strainers should be checked periodically and, if needed, cleaned as outlined under "INSPECTING AND CLEANING OF VALVE." To test controller for proper setting and operation—proceed as follows:

1. Place handle in hottest position. Mixing valve should deliver water at the temperature stamped on the label.

Standard setting is 110°F. If not 110°F, readjust to 110°F according to "TEMPERATURE ADJUSTMENT" procedure in another paragraph of this manual.

- a. If the temperature is below 110°F and the following procedures for adjusting do not increase temperature, see paragraph "CHECKING COLD WATER SHUT-OFF."
- b. If the temperature is above 110°F and the following procedures for adjusting do not decrease temperature, see paragraph "CHECKING HOT WATER SHUT-OFF."

Checking Cold Water Shut-Off

1. Turn adjustment handle to cold position. In this position a full flow of cold water should pass through the controller.
2. Shut the hot water stop valve and open cold water stop valve. Cold water should flow momentarily until thermostat cools and then flow should be reduced to a negligible amount with adjustment handle set to the warmest position.

Failure to do so will indicate that:

- a. Piston is sticking and unit must be cleaned.
- b. Spring has lost its strength and should be replaced.
- c. On first test, if water does not flow, this can be normal if temperature of cold water is below 75°F. A quick test is to momentarily turn on hot water so the thermostat warms up. If flow then starts, the thermostat is good. Failure to obtain flow when first starting or when valve is cold is a normal reaction.

Checking Hot Water Shut-Off

1. With adjustment handle set in hot position, mixing valve should deliver water at the temperature stamped on the nameplate.
2. Shut cold water supply to controller. The hot water should be reduced to a negligible amount.

Failure to do so will indicate:

- a. Hot water supply isn't 20°F above the required maximum temperature setting.
- b. Piston is sticking. Unit must be cleaned.
- c. Thermostat has lost charge.

Inspecting and Cleaning the Valve

Shut off hot and cold water supply to mixing valve. Set mixing valve handle on maximum hot position. Remove body screws. Turn mixing valve handle toward "COLD" position until it forces cover off valve body. The thermostat can now be examined.

Checking the Thermostat

If there is a question as to the thermostat being good, hold thermostat under cold water faucet and insert an eraser capped pencil into the center of thermostat. Make a reference mark where pencil protrudes from the thermostat. Now place the entire thermostat into hot water, approximately 125°F, for about one minute. Remove thermostat from water, examine the reference mark on the pencil again. At this temperature, it should extend out from former position about 1/8". If it does not, a new thermostat should be installed.

Checking the Piston and Liner

With a 13/8" socket (1/2" N.P.T.) or 1-5/8" socket (3/4" N.P.T.) remove piston and liner assembly. Check to see if the piston moves freely in the liner. If the piston is sticking, place the assembly in a mild acidic solution. Work the piston in the liner until free. Rinse the assembly in water. Be sure to wear protective gloves when cleaning the assembly. If the assembly is corroded or pitted, it should be replaced. Check O-ring #22 and replace if necessary.

Piston and liner assembly consists of parts included in assembly #12. (Only available as an assembly.)

Temperature Adjustment

Valves are normally set at the factory for 110°F maximum outlet temperature. If it is desired to change this setting, proceed as follows:

1. Allow water to flow through the controller.
2. Remove handle screw.
3. Turn adjustment handle to maximum hot position and hold in that position.
4. With narrow blade screw driver, turn adjusting screw #7 clockwise to reduce maximum outlet temperature and counter clockwise to increase maximum outlet temperature. Screw should not be turned more than 1/2 turn at a time without testing outlet water temperature.
5. When temperature is correct, replace handle screw.

If outlet temperature is to be 15°F or more higher than that on the label, contact factory or Lawler representative for a special thermostat.

Thermostatic Water Controller Cut-away

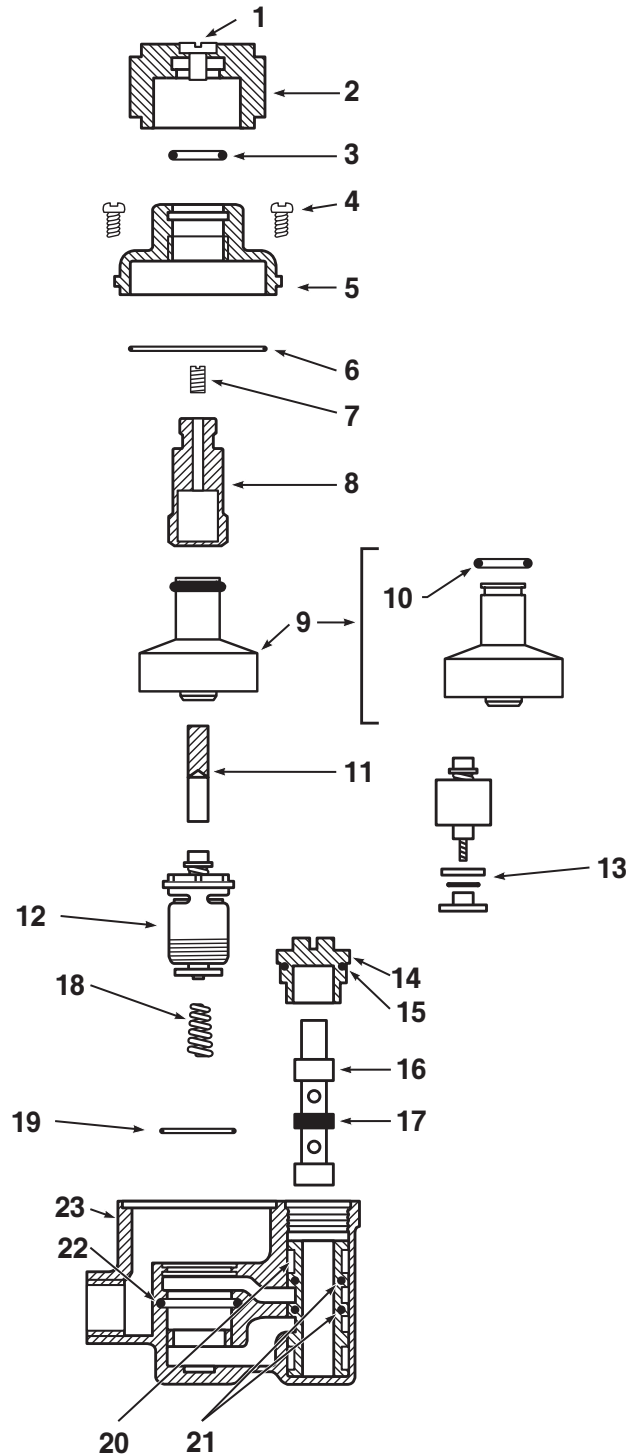

Complete Repair Kits

Valve	Part No.
67-10	78005-00
67-25	78006-00

Complete repair kits contain
3-4 (2)-6-9-11-12-13-15-16-17-18-19-20-21 (2)-22

WARNING: This product contains chemicals known to the State of California to cause cancer and birth defects or other reproductive harm.

(Installer: California law requires that this warning be given to the consumer.)

For more information: www.oehha.org/prop65

Item	Description	1/2" Part No.	3/4" Part No.
1	Handle Screw	7628-00	7628-00
2	Handle	8062-00	8062-00
3	Cover O-Ring	—	—
4	Cover Screw	1684-00	1684-00
5	Cover	—	—
6	Body Gasket	—	—
7	Adjusting Screw	8262-00	8262-00
8	Spindle	—	—
9	Thermostat	—	—
10	Thermostat Assembly	See Below	See Below
11	Pushrod	153-03	153-03
12	Piston, Liner & Backseat Assembly	See Below	See Below
13	Hot Seat Disc	—	—
14	Cylinder Cap	2782-00	3140-00
15	Cylinder Cap O-Ring	2782-00	3140-00
16	Shuttle	—	—
17	Shuttle O-Ring	—	—
18	Valve Spring	8223-00	8063-00
19	Liner Seat O-Ring	—	—
20	Shuttle Cylinder	—	—
21	Shuttle Cylinder O-Ring	—	—
22	Body O-Ring	—	—
23	Body	—	—

Numbers shown below are for a 1/2" 67-10 and 3/4" 67-25 with standard brass finish and temperature range of 85-135. Consult price sheets or contact the factory on kits with other flow rates and temperature ranges.

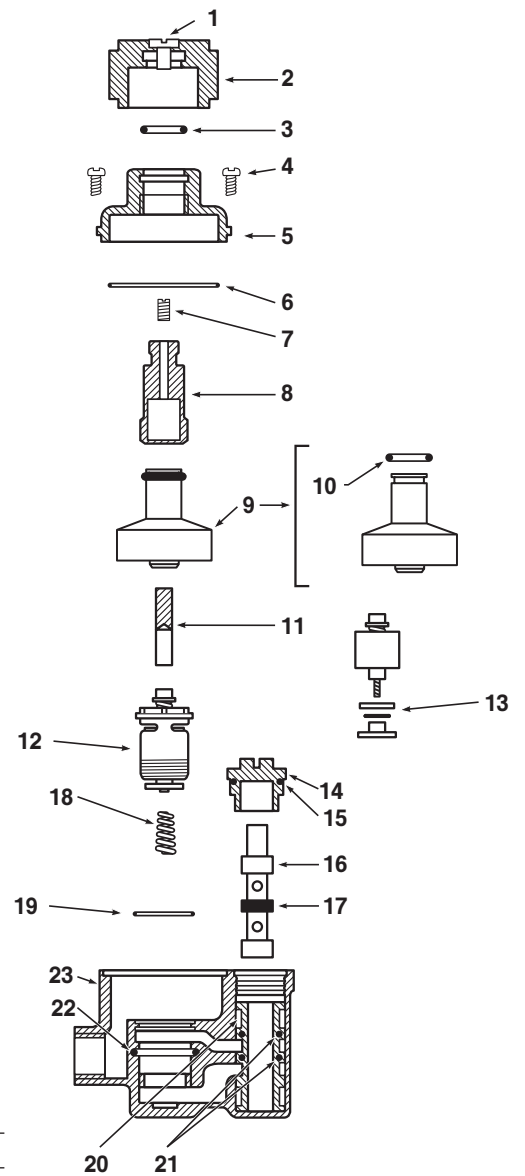

Repair Kits and Assemblies

Item	Description	Contains	67-10	67-25
A	Complete Repair Kit	B-C-D-F-4-11-18	78005-00	78006-00
B	O-Ring and Gasket Kit	3-6-10-13-15-17-19-21-22	79959-00	79960-00
C	Piston, Liner & Backseat	12	72904-01	72905-01
D	Thermostat Assembly	9-6	72903-01	72903-01
E	Cover & Spindle	3-5-6-7-8	72945-00	72946-00
F	Pressure Balancer	15-16-17-20-21(2)	71823-01	71824-00

Does not include parts for stop & checks

Rebuilding Kit for Inlet Stop & Checks

NOTE:* Components are not included in repair kit.

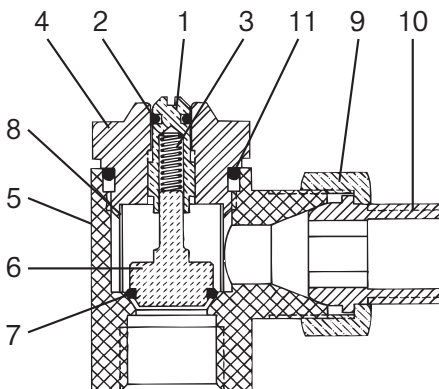

Item	Description
1	Adjustment Stem
2	O-Ring Seal
3	Spring
*4	Bonnet
*5	Body
6	O-Ring Disc Holder
7	O-Ring
8	Strainer
*9	Union Nut
*10	Union Tailpiece
11	Bonnet O-Ring

Repair Kit for Two Stop & Checks

Valve	Part No.
1/2"	79902-03
3/4"	79907-12

Typical Installation

Install the mixing valve below the hot water tank or heater. If this is not possible, pipe in a heat trap as shown in Figure 1 with an approximate 2' drop.

Connect a tempered water return line as shown in Figure 1. This allows flow through both ports of the mixing valve during periods of no draw.

Install an aquastat at the tempered water return pump.

Install the water heater per manufacturer's instructions.

Figure 1

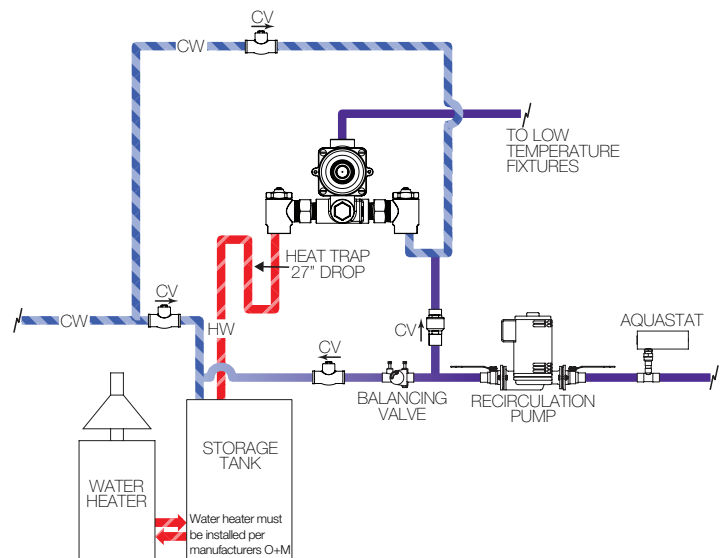

Setting The Mixing Valve To The System

1. After installations be sure to flush the system thoroughly.
2. Make sure the hot water supply is heated to normal design temperature.
3. Close and tag all fixtures to ensure they are not used during this procedure.
4. Turn off the recirculating pump.
5. Create a draw on the system greater than the minimum flow rating of the mixing valve. All open fixtures must be tagged to ensure they are not tampered with or used during this procedure.
6. Allow water to flow through the mixing valve until the water temperature is stable. If necessary, readjust the mixing valve in accordance with the TEMPERATURE ADJUSTMENT section of the installation manual.
7. Once the temperature is set, start the recirculating pump and allow the system to reach set temperature.
8. Measure the water temperature at the return pump and adjust the aquastat to shut off the pump should the return water exceed the set point by 2 degrees F. Set the low limit switch to restart the return pump when return water drops 5 degrees F below the set temperature.
9. Set the balancing valve in the full open position.
10. Shut off all fixtures and ensure there is no draw on the system. The cold inlet to the mixing valve should be warm.
11. Allow the system to run in this condition for at least 30 minutes.
12. In some cases, an increase in water temperature may occur during a no draw period. If this occurs, slowly close the balancing valve until the water temperature is back to the original set temperature.

GUARANTEE

We guarantee the Lawler Mixing Valve to be free from defects in workmanship and material, and for a period of one year from date of purchase, will replace any parts found by us to be defective. We will not be held responsible, however, for any labor incidental to, or for any damages caused by defective material. Each mixing valve is thoroughly inspected and tested under actual conditions at our factory.

