



Series 67 Combination Thermostatic and Pressure Balanced Water Controller Eng. No. 84508

CAPACITIES – GPM SERIES 67

| Pressure Drop PSI | 5 | 10 | 20 | 30 | 45 | 60 | 80 |
|-------------------|----------------|-----|-----|----|----|----|----|
| Valve Number | Capacity – GPM | | | | | | |
| 67-10 | 2.5 | 3.5 | 5.5 | 8 | 10 | 12 | 14 |
| 67-25 | 6 | 10 | 14 | 18 | 25 | 30 | 34 |

1/4 gpm when properly installed in recirculated system.

CAPACITIES – LPM SERIES 67

| Pressure Drop PSI | 5 | 10 | 20 | 30 | 45 | 60 | 80 |
|-------------------|----------------|------|------|------|------|------|-----|
| Valve Number | Capacity – LPM | | | | | | |
| 67-10 | 9.4 | 13.2 | 22.8 | 30.3 | 37.8 | 45.4 | 53 |
| 67-25 | 22.7 | 37.8 | 53 | 68 | 94.6 | 113 | 128 |

Minimum flow for 67-10 is 1/2 Gallon Per Minute
Minimum flow for 67-25 is 1 Gallon Per Minute

Exposed valve shall be a combination thermostatic and pressure-balanced mixing valve, with a liquid-filled motor. In the event of interruption of hot or cold water supply or thermostat failure, the valve shall be designed to restrict flow by use of a sliding piston control mechanism with a reverse seat closure. The valve shall maintain output temperature for changes in inlet pressure and temperature. Valve construction shall have lead free brass body and stainless steel piston and liner. Mixing valve shall include a union end stop and check valve with removable strainer on each inlet.

Unit is completely assembled as shown. Includes dial thermometer and shut-off on tempered water outlet.

FINISH: Brass
Rough Chrome
Other

VALVE: 1/2"
3/4"

| TEMP. RANGE | SET POINT | |
|---------------|-----------|--------------------------|
| 50° to 100°F | 80°F | <input type="checkbox"/> |
| 85° to 135°F | 110°F | <input type="checkbox"/> |
| 100° to 150°F | 130°F | <input type="checkbox"/> |
| Special _____ | _____ | <input type="checkbox"/> |

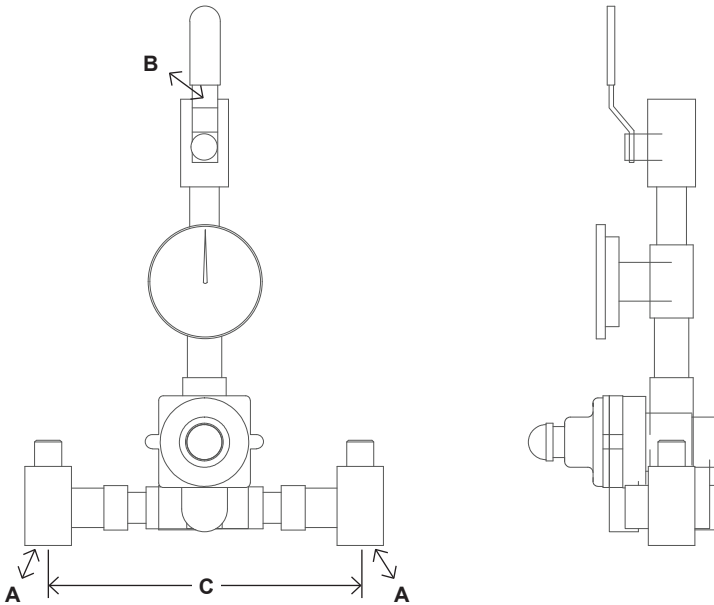

Series 67 Eng. No. 84508

Typical Installation

Install the mixing valve below the hot water tank or heater. If this is not possible, pipe in a heat trap as shown in Figure 1 with an approximate 2' drop.

Connect a tempered water return line as shown in Figure 1. This allows flow through both ports of the mixing valve during periods of no draw.

Install an aquastat at the tempered water return pump.

Install the water heater per manufacturer's instructions.

DIMENSIONS

| Valve Number | A | N.P.T. | B | N.P.T. | C |
|--------------|------|--------|------|--------|--------|
| 67-10 | 1/2" | | 1/2" | | 8" |
| 67-25 | 3/4" | | 3/4" | | 8-3/8" |

Dimensions are for reference purposes only. For rough-in dimensions please refer to Lawler's Revit/BIM models found at temperedwater.com.

Figure 1

