



Model 911[®]E/F Thermostatic Mixing Valve Emergency Eye/Fashwash Eng. No. 84909

CAPACITIES – MODEL 911E/F

Pressure Drop PSI	5	10	20	30	45
Tempered Flow GPM	2	3	5	7	10
Tempered Flow LPM	7.5	11	18	26	38

BYPASS CAPACITIES – MODEL 911E/F

Pressure Drop PSI	5	10	20	30	45
Cold Bypass GPM	1	2	4	5	7
Cold Bypass LPM	4	7.5	15	18	26

The Emergency Shower Mixing Valve shall employ a single control mechanism which split the flow in half, blend each half to the design temperature and then integrate each stream at the outlet. The valve shall control outlet temperature over a wide range of flow and shall be suitable for eye/eye face wash applications in order to comply with ANSI standard Z358.1. The valve shall include a single thermometer to measure the outlet temperature. Temperature adjustment shall be vandal-resistant.

The control mechanism shall employ a liquid-filled thermostatic motor to drive the valve without additional power requirements. The control mechanism shall employ a stainless steel sliding piston control device with reverse seat closure and both fixed and variable cold water bypass.

In the event of interruption of the cold water supply, each control mechanism closes off the hot water port, stopping all flow. Positive hot water shut-off. In the event of interruption of the hot water supply, each control mechanism shall allow cold flow through both the fixed and variable bypass.

In the event that one liquid motor fails, the control mechanism closes off the hot water port with the reverse seat and fully opens the internal variable bypass to allow cold water flow. The other control mechanism will be unaffected by the failure and will maintain design temperature.

Maximum Inlet Pressure: 125 PSI

Recommended Supply Pressure: 65 PSI

Recommended Inlet Temperature: 120°F

When supplying 140°F or greater, additional outlet controls should be used.

Set Point: 85°F

CAPACITY OF TYPE 911E/F THERMOSTATIC MIXING VALVE FOR EMERGENCY EYE/EYE/FACEWASH

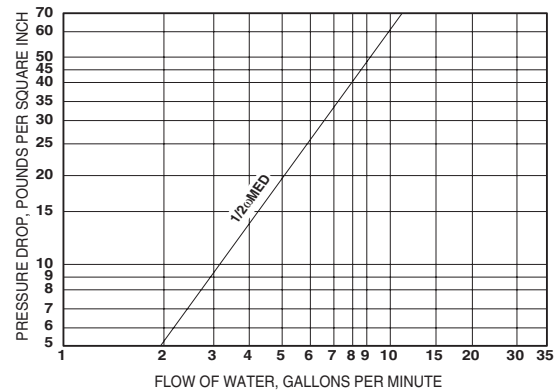

FINISH: Brass
Rough Chrome

Lock Set Mounting Bracket

Lock set includes lockable cover plate and keyed padlock to prevent unauthorized temperature adjustment. Unit includes 0-200°F dial thermometers, and inlet check valves.

CABINET SPECIFICATIONS:

	STAINLESS	CARBON STEEL
Body:	18 Ga.	16 Ga.
Door:	18 Ga.	16 Ga.
Material:	Type 304 with No. 4 Finish	Baked enamel painted

TYPE OF CABINET

Recessed
Semi-Recessed
Surface

MATERIAL

Stainless
Carbon Steel
Carbon Steel Box,
Stainless Door

Cabinet includes lock with two keys. Hinged left side, piano type. For specifications on security cabinets, contact factory.

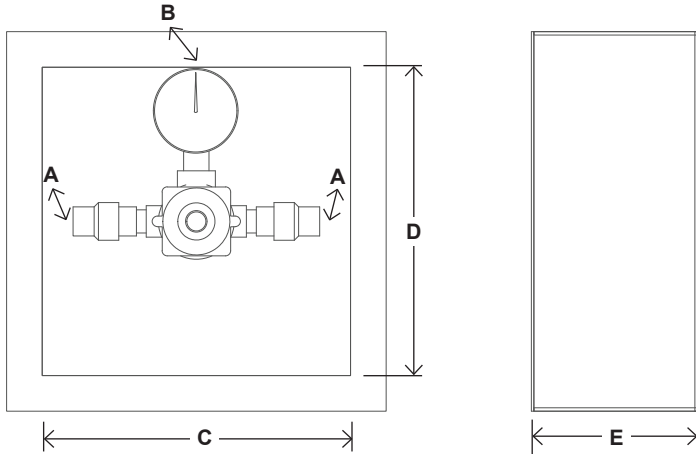

DIMENSIONS

Valve Number	A	N.P.T.	B	N.P.T.	C	D	E
911	1/2"		1/2"		14"	14"	6"

Dimensions are for reference purposes only. For rough-in dimensions please refer to Lawler's Revit/BIM models found at temperedwater.com. Add 1-1/2" for flange.

**Model 911[®]E/F
Eng. No. 84909**

Typical Installation Figure 1

When installed at or near the water heater and without a recirculation system:

Install the valve as shown in Figure 1 with the mixing valve positioned below the hot water tank or heater. If this is not possible, pipe in a heat trap as shown.

Typical Installation Figure 2

When installed away from the water heater with a recirculating pump on the hot water supply line:

Install the mixing valve as shown in Figure 2. The non-circulated loop should be limited to 10 feet and must be flushed periodically.

Notes: If the valve is installed 20 feet or more from the water heater, it is important to recirculate the hot water supply to the mixing valve.

The mixing valve must be installed with inlet check valves and the shower or the Eyewash/Facewash fixture should be installed 4 to 10 feet from the mixing valve. Hot and cold water inlet pressures must be equal.

Provisions shall be made to thermally isolate the valve.

Figure 1

Valve must be installed with check valves

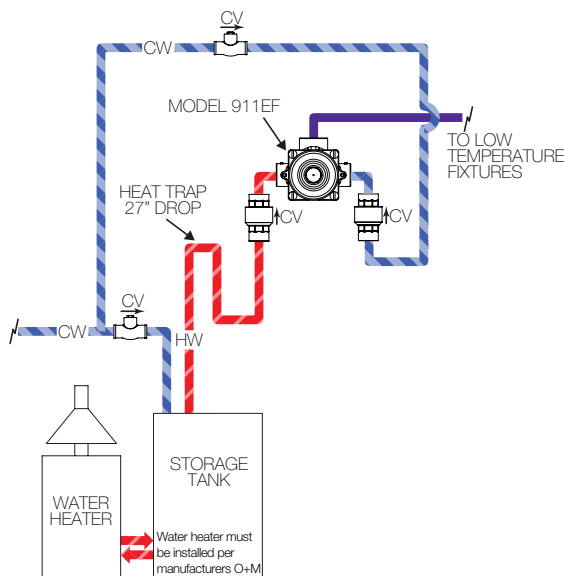

Figure 2

Valve must be installed with check valves

