



Model 802 Thermostatic Water Controller High-Low Water Mixer Eng. No. 86004

CAPACITIES – MODEL 802

Pressure Drop PSI	5	10	20	30	45	60	80
Valve Number	Capacity						
802-GPM	28	39	54	66	80	91	103
802-LPM	106	148	208	247	303	341	388

1/2 gpm when properly installed in recirculated system.

Master water mixing valve shall be of the thermostatic type with liquid-filled thermal motor. It shall have lead free brass body construction with replaceable corrosion-resistant components. Valve construction shall employ a sliding piston control mechanism. Sliding piston and liner shall be of stainless steel material. Valve shall come equipped with union end stop and check inlets with removable stainless steel strainers. Valve shall control temperature from a low flow of 2 GPM* up to a maximum flow rate for a given pressure differential. Valve shall provide protection against hot or cold supply line failure and thermostat failure.

Unit includes a dial thermometer and shut-off valve on tempered water outlet. Unit is assembled and tested with necessary fittings and nipples.

Also included is a valved cold water bypass line from the cold water supply line. All piping passes through the top of cabinet. Cabinet is shipped separately.

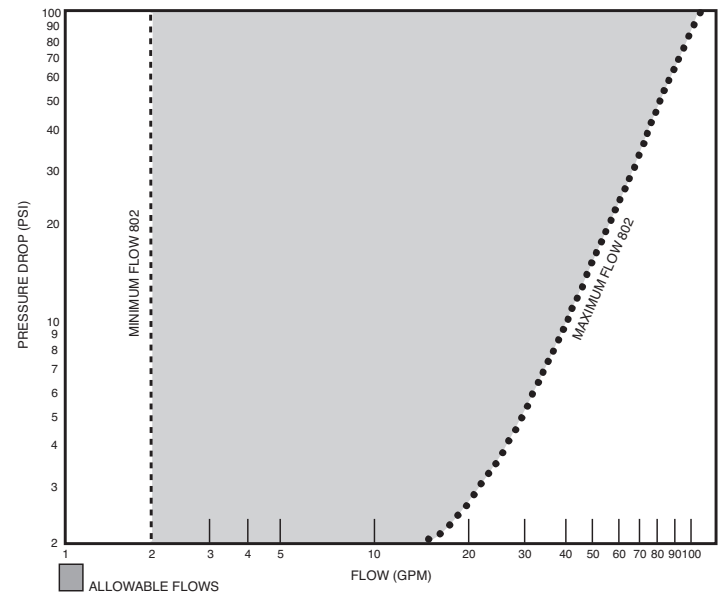

FINISH: Brass
Rough Chrome
Other

TEMP. RANGE	SET POINT	
70° to 100°F	80°F	<input type="checkbox"/>
90° to 120°F	110°F	<input type="checkbox"/>
110° to 140°F	130°F	<input type="checkbox"/>
Special _____	_____	<input type="checkbox"/>

Optional Test Connection
Including garden hose connection, shut-off and thermometer.

Brass
Rough Chrome

CABINET SPECIFICATIONS:

	STAINLESS	CARBON STEEL
Body:	18 Ga.	16 Ga.
Door:	18 Ga.	16 Ga.
Material:	Type 304 with No. 4 Finish	Baked enamel painted

TYPE OF CABINET

Recessed
Semi-Recessed
Surface

MATERIAL

Stainless
Carbon Steel
Carbon Steel Box, Stainless Door

Cabinet includes lock with two keys. Hinged left side, piano type. For specifications on security cabinets, contact factory.

Model 802 Eng. No. 86004

Typical Installation

Install the mixing valve below the hot water tank or heater. If this is not possible, pipe in a heat trap as shown in Figure 1 with an approximate 2' drop.

Connect a tempered water return line as shown in Figure 1. This allows flow through both ports of the mixing valve during periods of no draw.

If a dual temperature system is used, a separate recirculating loop and pump are required to return high temperature hot water to the water heater. See Figure 2.

Install an aquastat at the tempered water return pump.

Install the water heater per manufacturer's instructions.

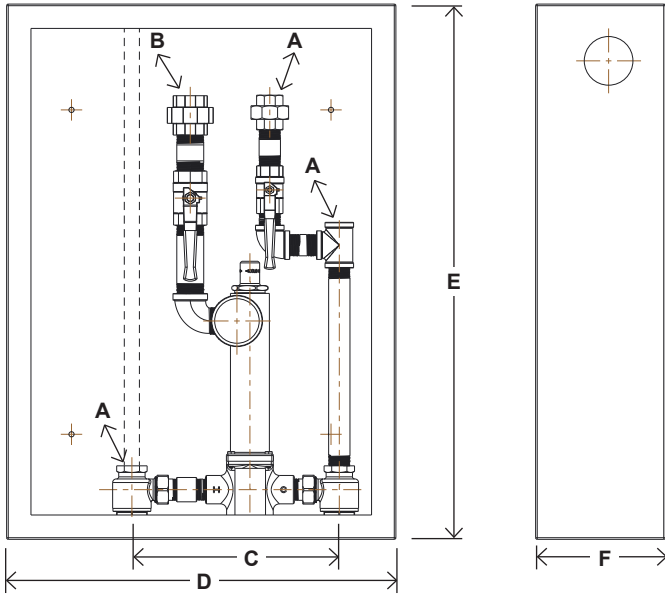

DIMENSIONS

Valve Number	A	N.P.T.	B	N.P.T.	C	D	E	F
802	1"		1-1/4"		12-3/4"	24"	33"	8"

Dimensions are for reference purposes only. For rough-in dimensions please refer to Lawler's Revit/BIM models found at temperedwater.com.

Figure 1

When used in a single temperature recirculating system

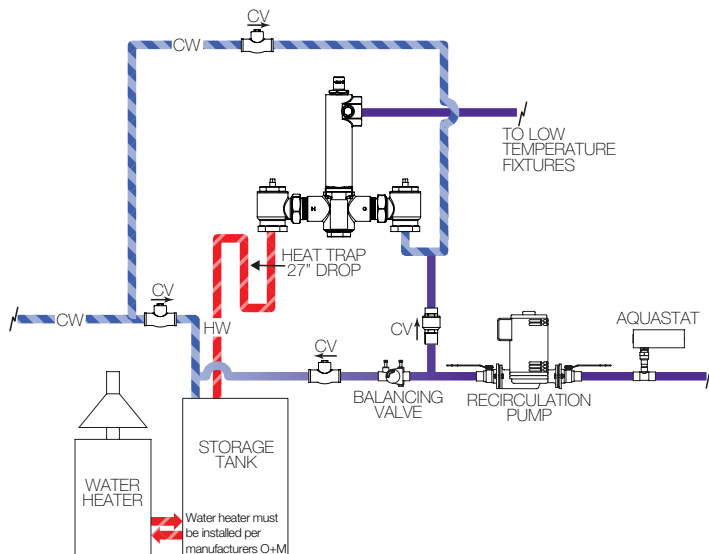

Figure 2

When used in a dual temperature recirculating system

