



Model 410-CAB Thermostatic Mixing Valve Eng. No. 86501

CAPACITIES – MODEL 410

Pressure Drop PSI	5	10	20	30	45	60
Valve Number	Capacity					
410-GPM	5	8	12	15	20	24
410-LPM	19	30	45	56	75	91

1/4 gpm when properly installed in recirculated system.
The minimum flow of the Series 410 is 1 GPM.

The master controller shall be of the thermostatic type with liquid-filled motor. The controller shall maintain the set point temperature during periods of fluctuating inlet pressures and temperatures. Valve construction will include a lead free brass body and replaceable corrosion-resistant components. The piston and liner are stainless steel. The mixing valve shall employ an adjustable setpoint range and high temperature limit stop. Each unit will be equipped with stop and check valves for each inlet and includes a dial thermometer. Cabinet is shipped separately.

FLOW CAPACITIES SINGLE STAGE - SERIES 410

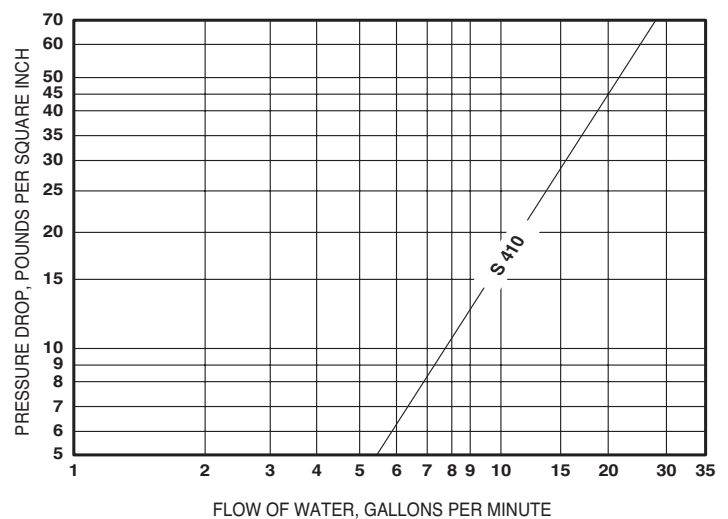

FINISH: Brass
Rough Chrome
Other

TEMP. RANGE **SET POINT**

50° to 100°F 80°F
85° to 135°F 110°F
100° to 150°F 130°F
Special _____

CABINET SPECIFICATIONS:

	STAINLESS	CARBON STEEL
Body:	18 Ga.	16 Ga.
Door:	18 Ga.	16 Ga.
Material:	Type 304 with No. 4 Finish	Baked enamel painted

TYPE OF CABINET

Recessed
Semi-Recessed
Surface

MATERIAL

Stainless
Carbon Steel
Carbon Steel Box,
Stainless Door

Cabinet includes lock with two keys. Hinged left side, piano type. For specifications on security cabinets, contact factory.

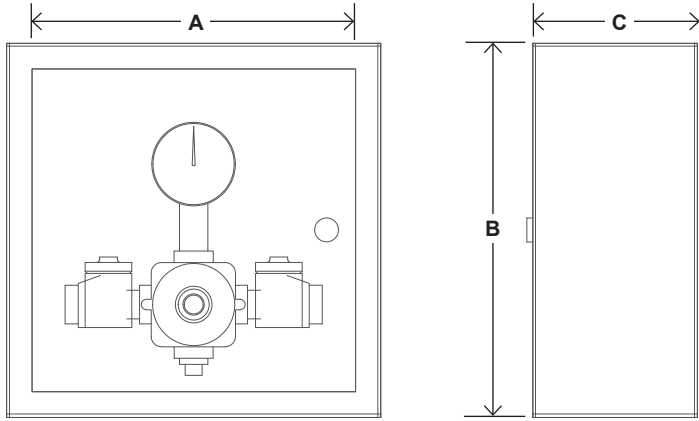

Model 410-CAB Eng. No. 86501

Typical Installation

Install the mixing valve below the hot water tank or heater. If this is not possible, pipe in a heat trap as shown in Figure 1 with an approximate 2' drop.

Connect a tempered water return line as shown in Figure 1. This allows flow through both ports of the mixing valve during periods of no draw.

Install an aquastat at the tempered water return pump.

Install the water heater per manufacturer's instructions.

DIMENSIONS

Valve Number	A	B	C
410	14"	14"	6"

Dimensions are for reference purposes only. For rough-in dimensions please refer to Lawler's Revit/BIM models found at temperedwater.com.

Inlets & outlet are 3/4" NPT. Add 4" to height and for flange.

Figure 1

