

# Neptune EMX 125 RP Electronic Mixing Valve with Recirculation Piping Eng. No. 943120

Pressure Drop PSI		5	10	20	30
Valve	Inlet Size	CAPACITY GPM			
NEPTUNE EMX 125	1-1/4"	41.4	58.6	83	101

Minimum flowrate: 1/4 gpm when properly installed at or near the hot water source recirculating tempered water with a properly sized continuously operating recirculation pump. (5 gpm min per valve)

- 1" inlets and outlet
- Stainless Steel Construction
- ASSE 1017 and NSF 372 (lead free) listed
- Maximum operating pressure: 150 psi
- Controls water temperature to +/- 2°F in accordance with ASSE 1017
- Low Load algorithm keeps temperature steady in low demand periods
- Fails "last position" during power failure
- Automatic Hot/Cold water shutoff upon cold/hot water inlet supply failure
- Recommended recirculation pipe size: 1" or greater
- System includes recirculation piping, circuit setting balancing valve and check valves
- Programmable high temperature alarm function
- Programmable set point range between 95°F to 180°F (Default set temperature 120°F)
- Control box supplied with 4 ft. 120 VAC power cord and NEMA 4 enclosure
- Modbus communication standard
- Easy integration into BMS system
- Operating Voltage: 24 VDC
- Simple user commissioning and setup
- Displays outlet temperature
- Removeable and serviceable thermocouple probe
- Factory Assembled and Tested
- Minimum hot water supply temperature: 2°F (1°C) above set point with equal incoming pressures

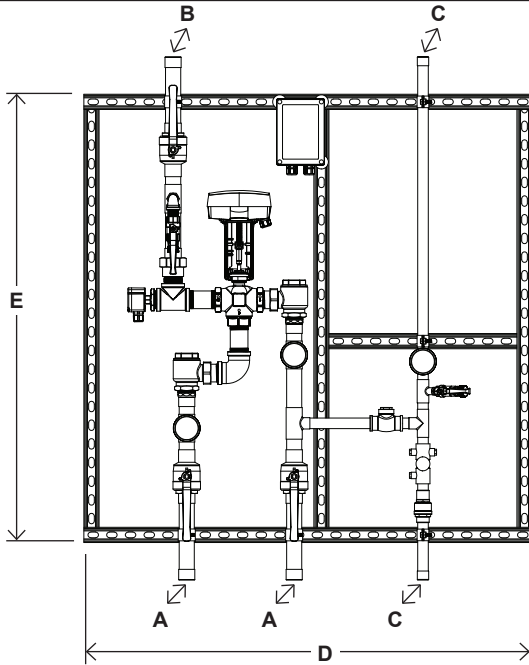

**DIMENSIONS**

Valve Number	A N.P.T.	B N.P.T.	C N.P.T.	D	E
EMX 125	1-1/4"	1-1/4"	1"	50"	50"

Dimensions are for reference purposes only. For rough-in dimensions please refer to Lawler's Revit/BIM models found at [temperedwater.com](http://temperedwater.com).

# Neptune EMX 125 RP Electronic Mixing Valve with Recirculation Piping Eng. No. 943120

## Typical Installation

Install the mixing valve below the hot water tank or heater. If this is not possible, pipe in a heat trap as shown in Figure 1 with an approximate 2' drop.

Connect a tempered water return line as shown in Figure 1. This allows flow through both ports of the mixing valve during periods of no draw.

If a dual temperature system is used, a separate recirculating loop and pump are required to return high temperature hot water to the water heater. See Figure 2.

Install the water heater per manufacturer's instructions.

**Figure 1**

**When used in a single temperature recirculating system**

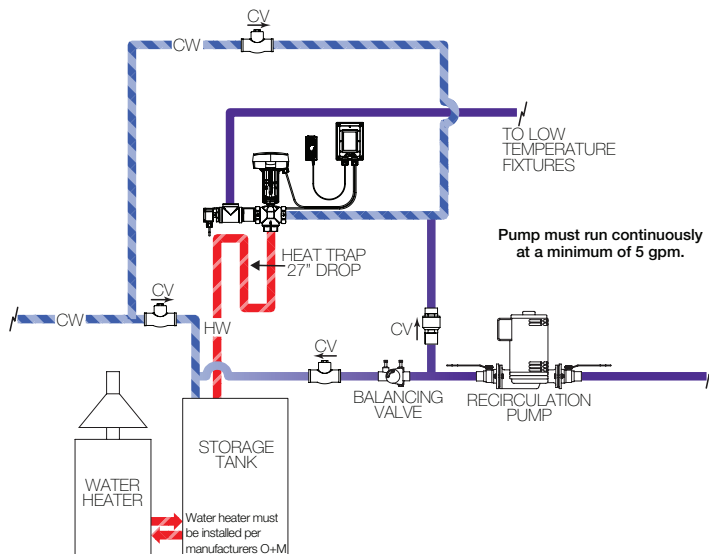

**Figure 2**

**When used in a dual temperature recirculating system**

