



MANUFACTURING CO., INC.
 5330 East 25th Street
 Indianapolis, Indiana 46218
 Phone (317) 261-1212
 Fax (317) 261-1208

www.lawlervalve.com

Installation &
 Maintenance Manual
 M 9600 B

Series 9600

NOTICE!

No mixing valve will work satisfactorily if improperly installed. We suggest, therefore, that you read these instructions carefully before installing and follow directions as outlined. Handle the mixing valve with care.

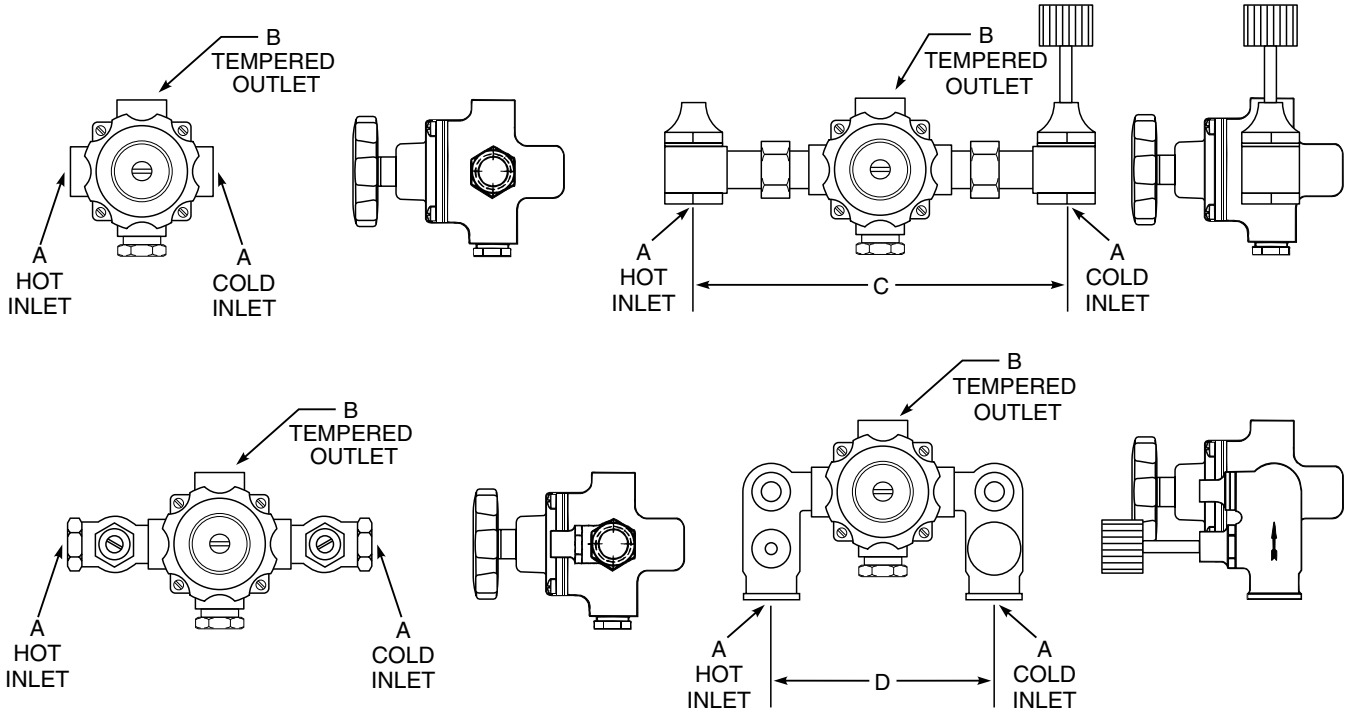

General Description For 1/2" and 3/4"

Mixing Valve

Valve is carefully assembled and tested at the factory and set to deliver water at any temperature between full cold and 105°F. Failure of the cold water supply will cause the hot water seat to close. The label on the valve cover is marked "HOT - COLD," so that the handle can be set accordingly.

When unit is not being used turn the handle toward COLD position fully to shut off all flow.

Stop and Check Valves (When Ordered)

Each inlet of the mixing valve has a screwdriver-adjustable check valve. Both the cold and hot water

DIMENSIONS:

A N.P.T.	B N.P.T.	C	D
1/2"	1/2"	8 1/2"	5 1/2"
3/4"	3/4"	10 1/4"	NA

FLOW CAPACITIES - SERIES 9200 & 9600

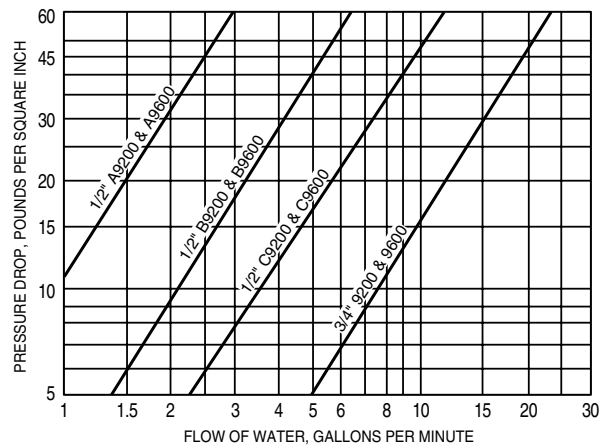

Caution: When maintaining and adjusting the mixing valve, all fixtures should be isolated from use. Lawler Manufacturing Co., Inc. recommends that you work safely at all times and in a manner consistent with the OSHA Lock/Tagout standard, 29 CFR 1910.147 and other applicable standards.

stop and check valves must be open at all times for proper functioning of the valve.

The stop and check valves serve three purposes:

1. They prevent the hot or cold water from bypassing through the mixing valve.
2. They provide convenient means to shut the supplies to the mixer for cleaning or repairs.
3. Their built-in removable strainers prevent dirt from entering mixing valve.

Note: Stop and checks are required whenever downstream shut off devices are used.

Temperature Adjustment

The temperature of the hot water supplying the mixing valve should be at least 15 degrees higher than maximum required valve setting. Valves are normally set at factory for 105°F maximum outlet temperature with 140°F inlet. If readjustment is required, proceed as follows:

1. Remove handle screw #1.
2. With narrow blade screwdriver, turn adjusting screw #2 clockwise to reduce maximum outlet temperature and counterclockwise to increase maximum outlet temperature. This must be done with valve handle in the hot position, turned counterclockwise. Screw should not be turned more than 1/2 turn at a time without testing water temperature.
3. When temperature is correct, replace handle screw.

Note: Adjusting screw #2 may not be turned counterclockwise more than 1 1/2 turns.

Caution: It is not recommended to set maximum outlet temperature above 115°F.

Piping Instructions

Before installing the mixer, blow out all pipe lines to be sure that no dirt, such as pipe chips, wicking or lead, can enter the mixing valve. Valve inlets are marked hot and cold. Piping must go to proper inlets.

Maintenance

The Lawler thermostatic mixer should be checked periodically for proper operation and cleaning. See "INSPECTING AND CLEANING OF VALVE." To test mixing valve for proper setting and operation—proceed as follows:

Checking Mixing Valve

1. Check swing movement of handle. Move handle to maximum HOT position counterclockwise. Short end should be pointed to hot, if not, remove handle screw, pull handle off and reset.
2. CHECKING COLD WATER SHUT-OFF. Shut off hot supply keeping cold supply open. Now move mixing valve handle 1/2 turn counterclockwise. A full volume of cold water should pass through

valve. Now move mixing valve handle as far as it will go counterclockwise. The volume of cold water should be reduced to a very small flow.

Failure of this to occur would indicate:

- a. Piston #11 is stuck in one position. Unit has to be cleaned.
 - b. Valve spring #13 has lost its strength and must be replaced.
 - c. Cold water is in excess of 80°F.
3. CHECKING HOT WATER SHUT-OFF. Open both the hot and cold supplies to mixing valve. Place handle at hottest position (turned all the way counterclockwise). Water should flow through valve at 105°F. If not, adjust valve as explained under "TEMPERATURE ADJUSTMENT."

Now shut off the cold water supply to the mixing valve. A properly operating mixer will shut off the hot water almost instantly with hot water temperature supplying the mixing valve at least 15 degrees higher than maximum setting.

Failure to do so would indicate:

- a. Dirt between the hot seat #12 in liner #16 and piston #11 prevents it from closing. Unit has to be cleaned.
 - b. The piston #11 could be stuck so that it cannot move because of scale or some other deposit in water. Unit has to be cleaned.
 - c. The thermostat has lost its power and has to be replaced with a new one.
 - d. On 3/4" valve only, if hot water pressure is over 50 p.s.i., valve may have a slight drip.
4. If a mixing valve will not shut off completely when handle is turned all the way clockwise check:
 - a. Cold seat #9 may be worn or dirty—clean or replace.
 - b. Seat of liner #16 could be eroded or cut—replace piston & liner.

If the handle is hard to turn, remove spindle #4 and polish with steel wool and lubricate with water insoluble grease or Vaseline. Check O-ring for imbedded foreign matter.

Inspection and Cleaning Valve

Shut off hot and cold water supply to mixing valve. Set mixing valve handle on maximum hot position. Remove body screws #5. Turn mixing valve handle toward cold position until it forces cover off valve body. The thermostat can now be examined.

Checking the Thermostat

If cold seat #9 on thermostat is worn or deeply indented, remove it and replace with a new one. If there is a question as to the thermostat being good, hold thermostat under cold water faucet and insert an eraser-capped pencil into the center of thermostat.

Make a reference mark where pencil protrudes from the thermostat. Now place the entire thermostat into hot water, approximately 125°F, for about one minute. Remove thermostat from water, examine the reference mark on pencil again. At this temperature, it should extend out from former position about 1/8". If it does not, a new thermostat should be installed.

Caution: Extreme care should be exercised when placing thermostat in and out of hot water.

Checking Piston and Liner

Remove piston assembly #11 from valve. Check the piston assembly and liner #16 for cleanliness and excessive wear. Check hot disc #12 for wear. Replace all worn parts.

Note: Liner #16 can be removed with a:

- 9/32" hex wrench for low flow 1/2" valves,
- 3/8" hex wrench for med & high flow 1/2" valves,
- 5/8" hex wrench for 3/4" valves.

Before reassembling the valve, thoroughly flush out with water.

Note: Piston Subassembly, consisting of parts #'s 11 17, 18, 12 and 14, are, factory pre-set with Liner #16 as a single unit.

Use only genuine factory parts for replacement of seat washers; thickness will affect the operation of the mixing valve.

When in need of Information

When writing the factory or one of its representatives in regard to a mixing valve, be sure to give the number appearing on the nameplate fastened to the dome.

Repair Kit

Valves can be completely rebuilt in a matter of minutes without removal from the line by installing a repair kit.

Warning: This product contains chemicals known to the State of California to cause cancer and birth defects or other reproductive harm.

(Installer: California law requires that this warning be given to the consumer.)

For more information: www.oehha.org/prop65

Series 9600 cut away

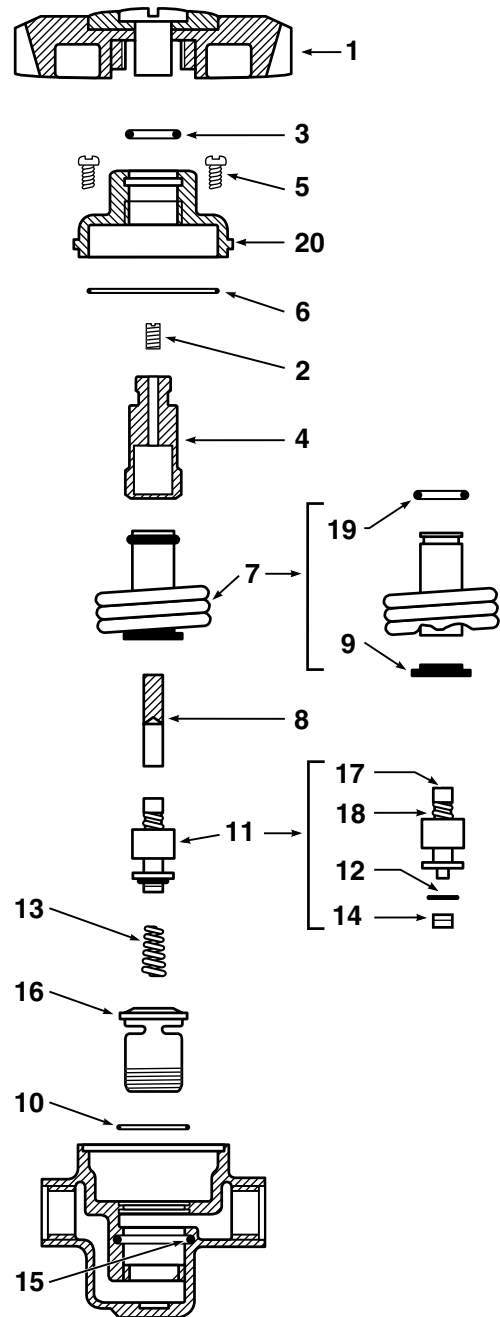

Repair Kits and Assemblies

Item	Description	Contains	1/2" Part No.	3/4" Part No.
A	Complete Repair Kit (1-5 GPM)	5-7-8-13-B-C	79853-02	79852-00
B	O-Ring and Gasket Kit	3-6-9-10-12-15-19	79959-30	79960-30
C	Piston and Liner Assy. (1-5 GPM)	10-11-16	72014-31	72014-35
D	Spindle and Cover Assy.	2-3-4-20 (brass) (chrome plated)	72005-02 72005-03	72006-02 72006-03
E	Shut Off	9	5410-00	71845-30
F	Thermostat Assy.	6-7	71870-32	71036-32

Note: Must specify capacity and finish of valve. Parts shown under 1/2" are for 1-5 GPM. All parts shown are for Plain Bronze finish.

Repair Kits for Inlet Stop & Checks

1/2" Stop

Part No. 7038-31
Repair Kit 79905-32

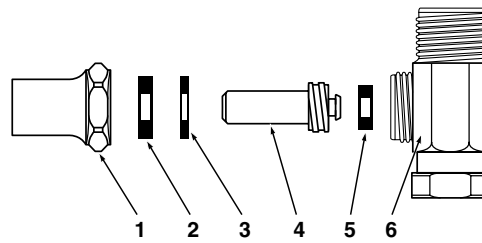

Item	Description
* 1	Bonnet
2	Packer
3	Washer
4	Stem Nose
5	Washer
* 6	Body

Item	Description
* 1	Bonnet
2	Packer
3	Washer
4	Stem
5	Spring
6	Nose
7	Washer
* 8	Body

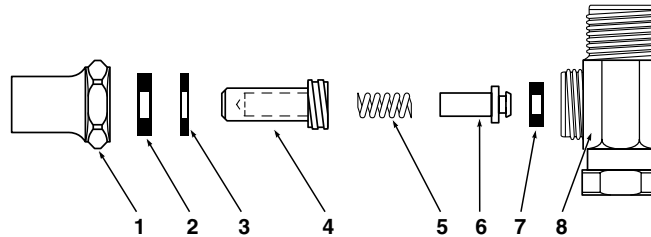

1/2" Stop & Check

Part No. 6839-31
Repair Kit 79905-32

1/2" Angled Stop & Check with Strainer

Part No. 70484-00
Repair Kit 79922-32

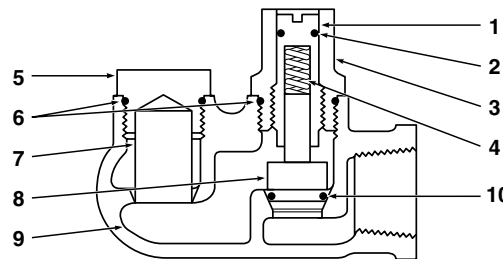

Item	Description
1	Adjustment Stem
2	O-Ring Seal
* 3	Bonnet
4	Spring
* 5	Strainer Plug
6	O-Ring Gasket
7	Strainer
8	Strainer Disc Holder
* 9A	Body (Right Hand)
* 9B	Body (Left Hand)
10	O-Ring Disc

Item	Description
* 1	Bonnet
2	Adjustment stem
3	O-Ring
4	Spring
5	Bonnet O-Ring
6	O-Ring
* 7	Body
8	O-Ring Disc Holder
9	Strainer
* 10	Union Nut
* 11	Union Tailpiece

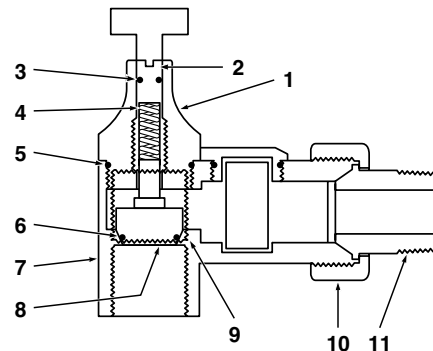

3/4" Union Angled Stop & Check with Strainer

Part No. 72661-30
Repair Kit 79894-32

1/2" Union Angled Stop & Check with Strainer

Part No. 72661-10
Repair Kit 79902-11

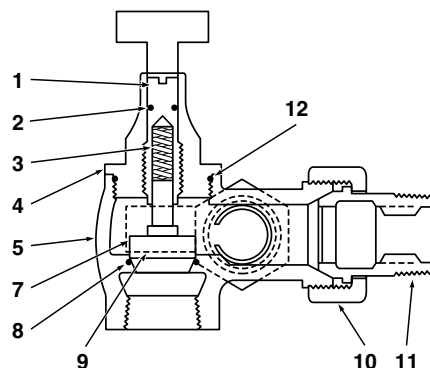

Item	Description
1	Adjustment Stem
2	O-Ring Seal
3	Spring
* 4	Bonnet
* 5	Body
7	O-Ring Disc Holder
8	O-Ring
9	Strainer
* 10	Union Nut
* 11	Union Tailpiece
12	Bonnet O-Ring

NOTE: * Components are not included in repair kit.

GUARANTEE

We guarantee the Lawler Mixing Valve to be free from defects in workmanship and material, and for a period of one year from date of purchase, will replace any parts found by us to be defective. We will not be

held responsible, however, for any labor incidental to, or for any damages caused by defective material. Each mixing valve is thoroughly inspected and tested under actual conditions at our factory.