



Thermostatic Water Controller Model 805[®] High-Low Water Mixer

Unit No. 73100



Certified to
CSA B125.3

ASSE 1017 Approved

Master water mixing control valve shall be of the thermostatic type with liquid-filled motor. It shall have bronze body construction with replaceable corrosion-resistant components. Valve construction shall employ sliding piston control mechanism. Piston and liner shall be of stainless steel material. Valve shall come equipped with removable union end stop and check inlets with stainless steel strainers. Valve shall control temperature from a low flow of 5 GPM* up to a maximum flow rate for a given pressure differential. Valve shall provide protection against hot or cold supply line failure and thermostat failure.

FINISH: **Bronze**
 Chrome
 Other

TEMP. RANGE **SET POINT**

70° to 100°F 80°F
 90° to 120°F 110°F
 110° to 140°F 130°F

Special _____

Optional Test Connection
 Including garden hose connection, shut-off and thermometer.

Bronze
Chrome

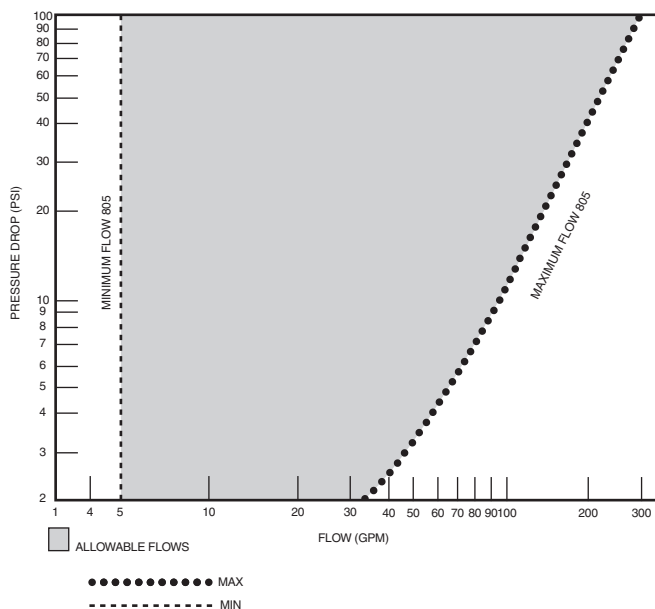

CAPACITIES - MODEL 805

Pressure Drop PSI	5	10	20	30	45	60	80
Valve Number	Capacity						
805-GPM	64	96	133	165	200	230	265
805-LPM	242	363	503	624	757	870	1003

*1/2 gpm when properly installed in recirculated system.



MANUFACTURING CO., INC.

5330 East 25th Street
 Indianapolis, Indiana 46218
 Phone (317) 261-1212
 Fax (317) 261-1208

Design and specification subject to change without notice.
 Please refer to www.temperedwater.com to ensure most current data sheet and other design solutions

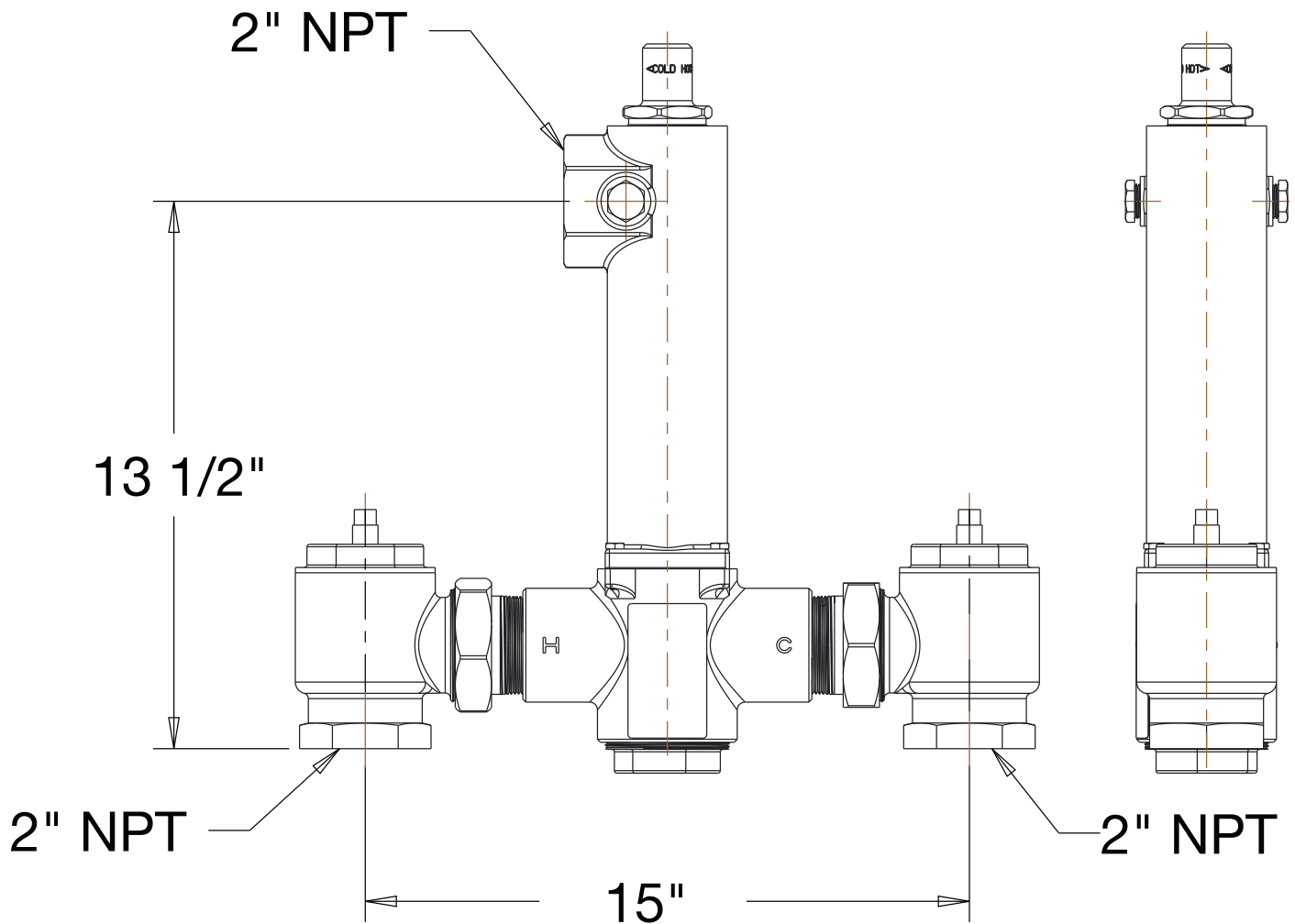

MANUFACTURING CO., INC.

5330 East 25th Street
Indianapolis, Indiana 46218
Phone (317) 261-1212
Fax (317) 261-1208

Design and specification subject to change without notice.
Please refer to www.temperedwater.com to ensure
most current data sheet and other design solutions