



MANUFACTURING CO., INC.

5330 East 25th Street
Indianapolis, Indiana 46218
Phone (317) 261-1212
Fax (317) 261-1208

www.lawlervalve.com

Installation &
Maintenance Manual
M EWV F
PAT. NO. 5,011,074.
PAT. NO. 5,379,936.

Series 911[®]E

Drench Shower & Eye Wash Valve

 ASSE 1071 Approved

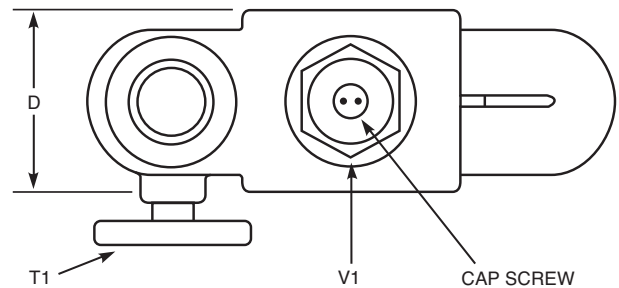
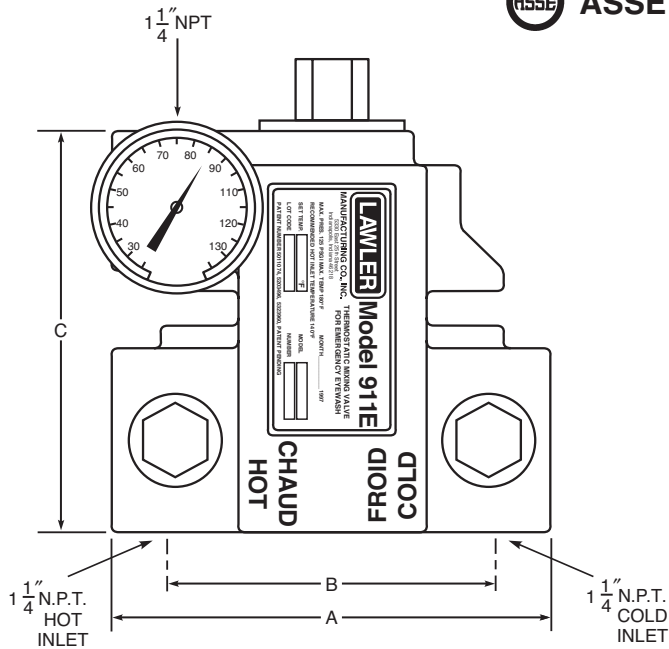

DIMENSIONS:

Valve Number	A	B	C	D
911E	7"	5"	6 1/2"	3"

CAPACITIES - SERIES 911E

Pressure Drop PSI	5	10	20	30	45
Tempered Flow	9	13	17	25	27
Cold Water Bypass	7	10	14	21	22

Caution: When maintaining and adjusting the mixing valve, the delivered flushing fluid temperature shall be 60°F (15°C) to 95°F (35°C). In circumstances where chemical reaction is accelerated by flushing fluid temperature, a medical advisor should be consulted for the optimum temperature for each application.

Setting the Mixing Valve

Caution: When maintaining and adjusting the mixing valve, all fixtures should be isolated from use. Lawler Manufacturing Co., Inc. recommends that you work safely at all times and in a manner consistent with the OSHA Lock/Tagout standard, 29 CFR 1910.147 and other applicable standards.

This mixing valve has been set at the factory to deliver 85°F outlet flow. Should the valve require adjustment, or an application require a different set temperature, proceed as follows:

1. Contact the proper medical and safety authorities to determine the correct water temperature for the specific application.

2. Use a spanner wrench to remove the tamper-resistant cap screw.
3. Create a draw on the mixing valve by opening a downstream eye wash fixture.
4. Insert a 5/32" allen key into the cap opening of the valve (V1) and seat in the adjustment screw (not shown). Set the outlet temperature by turning the adjustment screw clockwise to reduce temperature, counterclockwise to increase temperature. Use the dial thermometer (T1) to measure the outlet temperature.
5. Replace cap screw.

Note: Valve must be installed with check valves. If shut off valves are installed in the shower line for maintenance purposes, provisions shall be made to prevent unauthorized shut off.

Testing the Mixing Valve

The mixing valve and the emergency fixtures it serves should be tested weekly for proper operation.

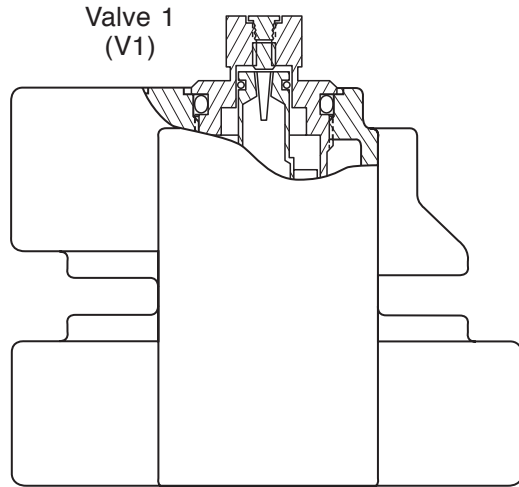

Valve temperature test procedure is as follows:

1. Activate eye wash fixture to observe and record the temperature of the dial thermometer (T1). If the temperature of the thermometer is not correct, readjust the mixing valve according to the section "Setting the Mixing Valve".
2. Observe the flow from the emergency fixtures to ensure an adequate flow of water.

In addition to testing for proper temperature, the cold water by-pass and hot water shut down features of the mixing valve should be tested weekly.

The test procedure is as follows:

1. Test valve temperature as described in Step 1 and Step 2 above.
2. Shut off the hot water supply to the mixing valve. Observe the outlet flow from the emergency fixtures to ensure an adequate flow of cold water. A slight drop in flow may occur after shutting down the hot water supply to the mixing valve, however, the drop should be minimal and for a short duration.
3. Open the hot water supply to the mixing valve. The thermometer should return to the set temperature.
4. Shut off the cold water supply to the mixing valve. The flow of water should shut down rapidly.
5. Open the cold water supply. The thermometer should return to the set temperature.

Note: The thermometer (T1) should be checked at least every six months.

Replacing the Thermostat Cartridge

The thermostat replacement procedure is as follows:

Note: Lawler Manufacturing Co., Inc. recommends that you work safely at all times and in a manner consistent with the OSHA Lock/Tagout standard, 29 CFR 1910.147 and other applicable standards.

1. Shut off the hot water supply and cold water supply to the mixing valve.
2. Unscrew valve cartridge (V1) and install a new cartridge assembly.
3. Open the hot water supply and the cold water supply to mixing valve. Check the temperature to see if the replacement cartridge is operating correctly. If the temperature requires adjustment refer to the section "Setting the Mixing Valve."

Operating Principle

This Series 911 Emergency Shower and Eye Wash mixing valve is made of a thermostat housed in a brass casting. The thermostatic cartridge responds to temperature changes in the hot and cold water supplies. The Series 911E valve requires testing and maintenance on a regular basis. In the event the element fails the valve should provide full cold water flow.

CAPACITY OF TYPE 911E THERMOSTATIC MIXING VALVE FOR EMERGENCY SHOWER AND EYEWASH

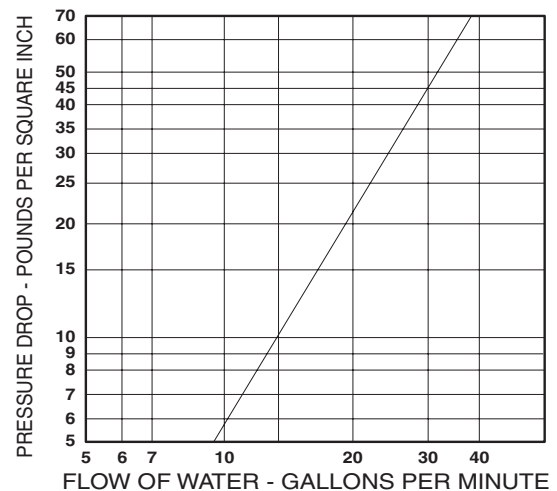

Note: Gallon per minute ratings may vary depending upon incoming water temperatures and pressures. Hot and cold water inlet pressures must be equal.

Maximum Inlet Pressure: 125 PSI.

Recommended Supply Pressure: 65 PSI.

Recommended Inlet Temperature: 120°F.*

*When supplying 140°F or greater, additional outlet controls should be used.

Installation

After installing the mixing valve, be sure to flush the system thoroughly. Lawler recommends isolation and check valves for proper maintenance.

Typical Installation *Figure 1*

When installed at or near the water heater and without a recirculation system:

Install the valve as shown in *Figure 1* with the mixing valve positioned below the hot water tank or heater. If this is not possible, pipe in heat trap as shown.

Typical Installation *Figure 2*

When installed away from the water heater with a recirculating pump on the hot water supply line:

Note: If the valve is installed 20 feet or more from the water heater, it is important to recirculate the hot water supply to the mixing valve.

Install the mixing valve as shown in *Figure 2*. The non-circulated loop should be limited to 10 feet and must be flushed periodically.

Warning: This product contains chemicals known to the State of California to cause cancer and birth defects or other reproductive harm.

(Installer: California law requires that this warning be given to the consumer.)

For more information: www.oehha.org/prop65

Caution: The cold water line must be installed so that it is not affected by excessively hot ambient temperatures. Provisions shall be made to thermally isolate the valve. Cold water pipe installed in the ceilings of boiler rooms or rooms that increase ambient temperature require a recirculating pump.

Note: The mixing valve must be installed with inlet check valves and the shower or the Eyewash/Facewash fixture should be installed 4 to 10 feet from the mixing valve.

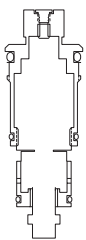

Cartridge Kit
Part Number 8334-50

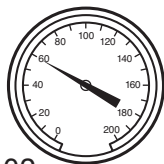

Thermometer
Part Number 6679-02

Figure 1
Typical installation. Valve must be installed with check valves.

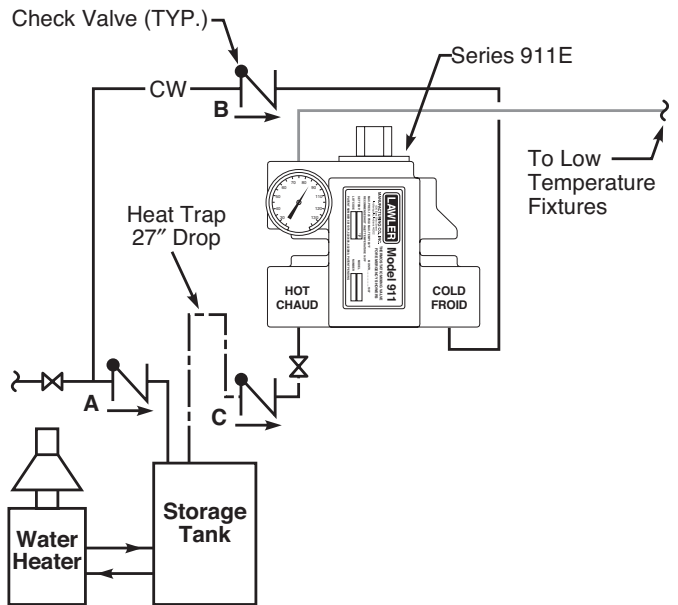
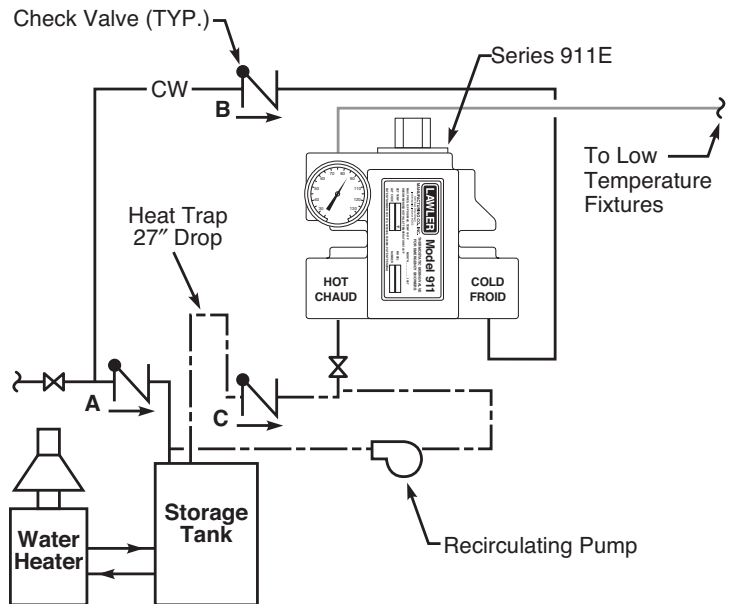

Figure 2
Typical recirculating installation. Valve must be installed with check valves.



GUARANTEE

We guarantee the Lawler Mixing Valve to be free from defects in workmanship and material, and, for a period of one year from date of purchase, will replace any parts found by Lawler Manufacturing Co., Inc. to be defective. We will not be held

responsible, however, for any labor incidental to, or for any damages caused by, defective material. Each mixing valve is thoroughly inspected and tested under actual conditions at our factory.

Series 911E Test Record

Location _____

Date		T1	YEAR	Date		T1	YEAR	Date		T1
Jan				YEAR	July				YEAR	Jan
Feb			Aug				Feb			
March			Sept				March			
April			Oct				April			
May			Nov				May			
June			Dec				June			
July			Jan				July			
Aug			Feb				Aug			
Sept			March				Sept			
Oct			April				Oct			
Nov			May				Nov			
Dec			June				Dec			
Jan			YEAR	July			YEAR	Jan		
Feb				Aug				Feb		
March				Sept				March		
April				Oct				April		
May				Nov				May		
June				Dec				June		
July				Jan				July		
Aug				Feb				Aug		
Sept				March				Sept		
Oct				April				Oct		
Nov				May				Nov		
Dec				June				Dec		
Jan			YEAR	July			YEAR	Jan		
Feb				Aug				Feb		
March				Sept				March		
April				Oct				April		
May				Nov				May		
June				Dec				June		

Before you use this chart please make a copy for future testing records.