



Model 804 Thermostatic Water Controller High-Low Water Mixer Eng. No. 73005

CAPACITIES – MODEL 804

Pressure Drop PSI	5	10	20	30	45	60	80
Valve Number	Capacity						
804-GPM	52	72	100	124	150	174	193
804-LPM	197	273	379	469	568	659	731

1/2 gpm when properly installed in recirculated system.

Master water mixing valve shall be of the thermostatic type with liquid-filled thermal motor. It shall have lead free brass body construction with replaceable corrosion-resistant components. Valve construction shall employ a sliding piston control mechanism. Sliding piston and liner shall be of stainless steel material. Valve shall come equipped with union end stop and check inlets with removable stainless steel strainers. Valve shall control temperature from a low flow of 4 GPM* up to a maximum flow rate for a given pressure differential. Valve shall provide protection against hot or cold supply line failure and thermostat failure.

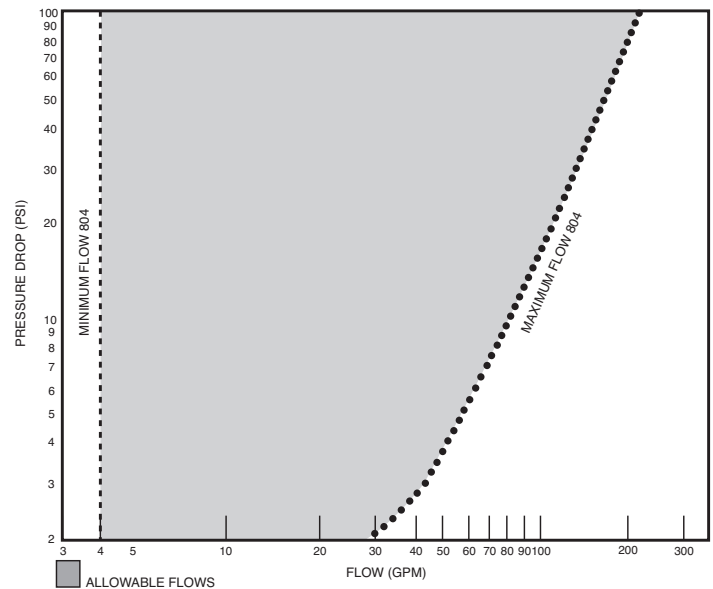

FINISH: Brass
Rough Chrome
Other

TEMP. RANGE **SET POINT**

70° to 100°F 80°F
90° to 120°F 110°F
110° to 140°F 130°F
Special _____

Optional Test Connection
Including garden hose connection, shut-off and thermometer.

Brass
Rough Chrome

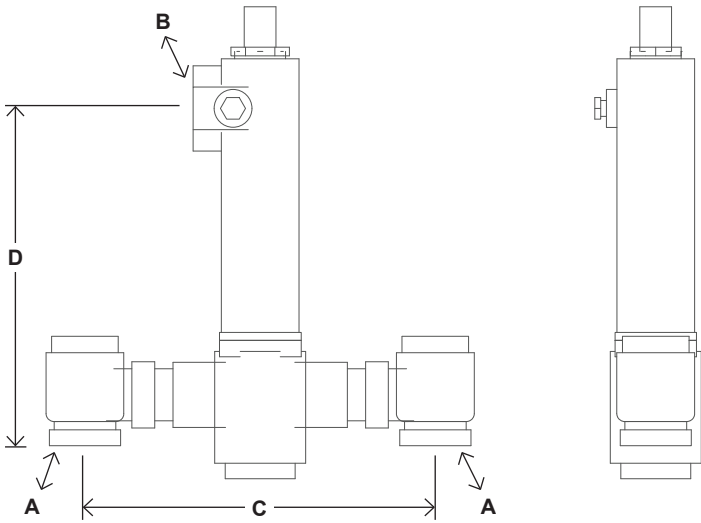

DIMENSIONS

Valve Number	A	N.P.T.	B	N.P.T.	C	D
804	1-1/2"		2"		15"	13-1/2"

Dimensions are for reference purposes only. For rough-in dimensions please refer to Lawler's Revit/BIM models found at temperedwater.com.

**Model 804
Eng. No. 73005**

Typical Installation

Install the mixing valve below the hot water tank or heater. If this is not possible, pipe in a heat trap as shown in Figure 1 with an approximate 2' drop.

Connect a tempered water return line as shown in Figure 1. This allows flow through both ports of the mixing valve during periods of no draw.

If a dual temperature system is used, a separate recirculating loop and pump are required to return high temperature hot water to the water heater. See Figure 2.

Install an aquastat at the tempered water return pump.

Install the water heater per manufacturer's instructions.

Figure 1

When used in a single temperature recirculating system

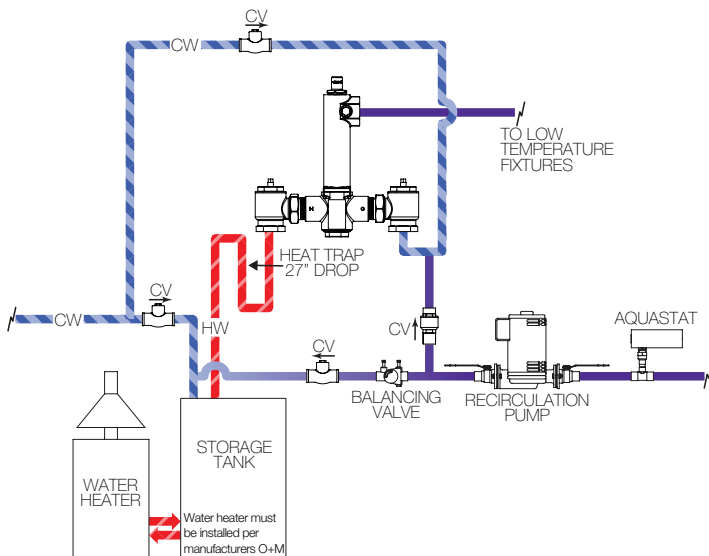

Figure 2

When used in a dual temperature recirculating system

