

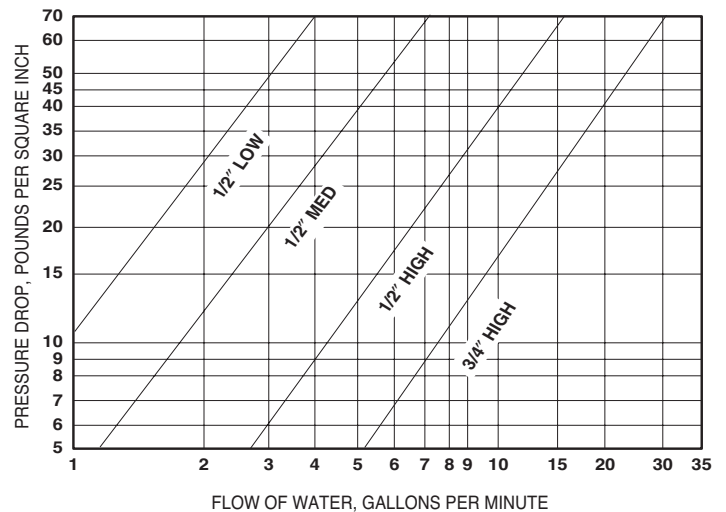

Model 7900 Concealed Thermostatic & Pressure Balanced Shower Valve

Eng. No. 75147 (1/2")
Eng. No. 72505 (3/4")

FLOW CAPACITIES DOUBLE STAGE - SERIES 7000



Concealed combination pressure balanced and thermostatically controlled mixing valve with stainless steel trim and solid brass polished chrome lever handle.

The Lawler concealed combination pressure balanced and thermostatically controlled mixing valve consists of independent pressure balancing and thermostatic control sections contained in one lead free brass body. The valve's piston and liner are constructed of stainless steel material. The thermostat is solid liquid filled. The mixing valve has integral shut-off and is adjustable from cold to 115°F unless otherwise specified. The valve employs an adjustable temperature limit stop.

The wall trim includes round stainless steel escutcheon with a solid brass, polished chrome lever handle. ADA compliant

Standard valve is 1/2" medium flow

OPTIONS:

- Suffix VR – Vandal resistant handle screw
- Prefix H – High flow 4-10 GPM
- Prefix M – Standard flow 1-5 GPM
- Prefix L – Low flow 1/2 – 2-1/2 GPM

7900 less stop & check valves

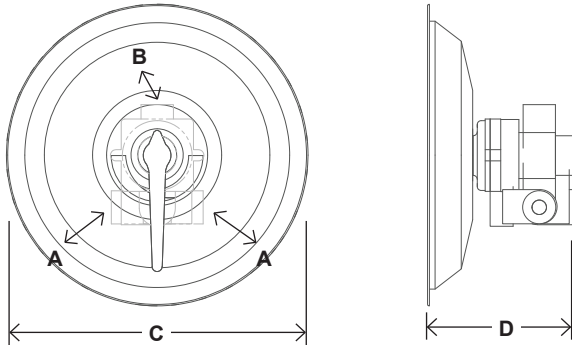

Model 7900
Eng. No. 75147 (1/2")
Eng. No. 72505 (3/4")

DIMENSIONS

Valve Number	A	N.P.T.	B	N.P.T.	C	D
7900		1/2"		1/2"	10-1/2"	6"

Dimensions are for reference purposes only. For rough-in dimensions please refer to Lawler's Revit/BIM models found at temperedwater.com.

7900-SC1 with straight stop & check valves

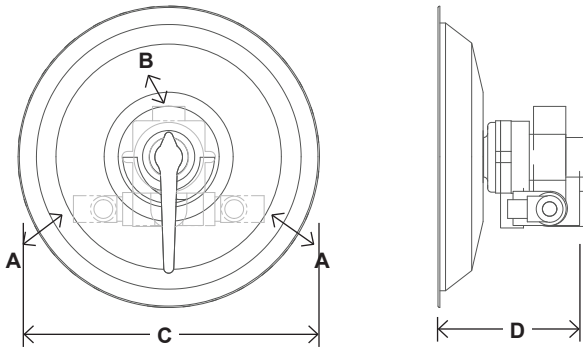

DIMENSIONS

Valve Number	A	N.P.T.	B	N.P.T.	C	D
7900-SC1		1/2"		1/2"	10-1/2"	6"

Dimensions are for reference purposes only. For rough-in dimensions please refer to Lawler's Revit/BIM models found at temperedwater.com.

7900-SC5 with strainer in angle check valves

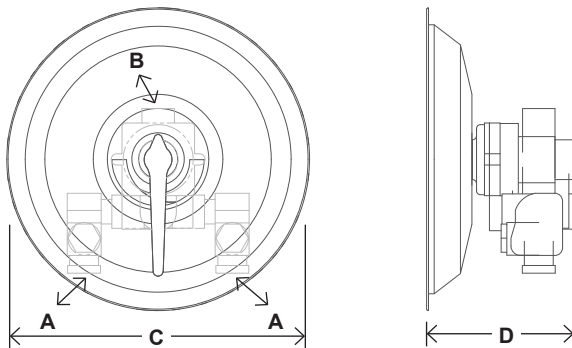

DIMENSIONS

Valve Number	A	N.P.T.	B	N.P.T.	C	D
7900-SC5		1/2"		1/2"	10-1/2"	6"

Dimensions are for reference purposes only. For rough-in dimensions please refer to Lawler's Revit/BIM models found at temperedwater.com.