



# Model 805<sup>®</sup> Thermostatic Water Controller High-Low Water Mixer Eng. No. 86108

## CAPACITIES – MODEL 805

Pressure Drop PSI	5	10	20	30	45	60	80
Valve Number	Capacity						
<b>805-GPM</b>	64	96	133	165	200	230	265
<b>805-LPM</b>	242	363	503	624	757	870	1003

1/2 gpm when properly installed in recirculated system.

Master water mixing valve shall be of the thermostatic type with liquid-filled thermal motor. It shall have lead free brass body construction with replaceable corrosion-resistant components. Valve construction shall employ a sliding piston control mechanism. Sliding piston and liner shall be of stainless steel material. Valve shall come equipped with union end stop and check inlets with removable stainless steel strainers. Valve shall control temperature from a low flow of 5 GPM\* up to a maximum flow rate for a given pressure differential. Valve shall provide protection against hot or cold supply line failure and thermostat failure.

Unit includes a dial thermometer and shut-off valve on tempered water outlet. Unit is assembled and tested with necessary fittings and nipples.

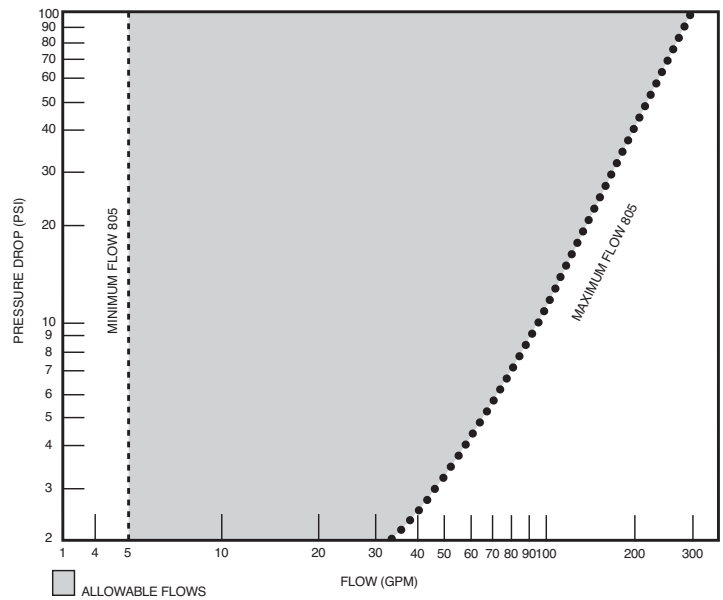

- FINISH:** Brass   
 Rough Chrome   
 Other

- | TEMP. RANGE   | SET POINT |                          |
|---------------|-----------|--------------------------|
| 70° to 100°F  | 80°F      | <input type="checkbox"/> |
| 90° to 120°F  | 110°F     | <input type="checkbox"/> |
| 110° to 140°F | 130°F     | <input type="checkbox"/> |
| Special _____ | _____     | <input type="checkbox"/> |

- Optional Test Connection**   
 Including garden hose connection, shut-off and thermometer.
- Brass   
 Rough Chrome

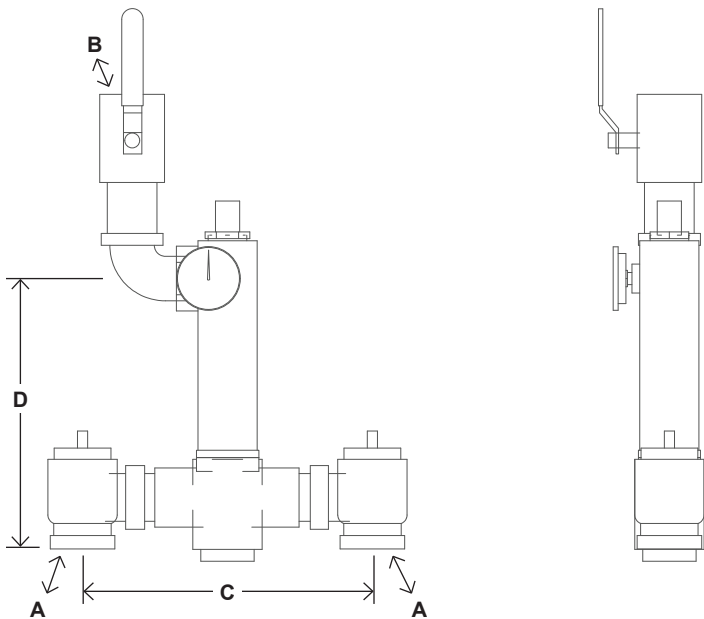

**DIMENSIONS**

Valve Number	A	N.P.T.	B	N.P.T.	C	D
805	2"		2"		15"	13-1/2"

Dimensions are for reference purposes only. For rough-in dimensions please refer to Lawler's Revit/BIM models found at [temperedwater.com](http://temperedwater.com).

**Model 805®  
Eng. No. 86108**

**Typical Installation**

Install the mixing valve below the hot water tank or heater. If this is not possible, pipe in a heat trap as shown in Figure 1 with an approximate 2' drop.

Connect a tempered water return line as shown in Figure 1. This allows flow through both ports of the mixing valve during periods of no draw.

If a dual temperature system is used, a separate recirculating loop and pump are required to return high temperature hot water to the water heater. See Figure 2.

Install an aquastat at the tempered water return pump.

Install the water heater per manufacturer's instructions.

**Figure 1**

**When used in a single temperature recirculating system**

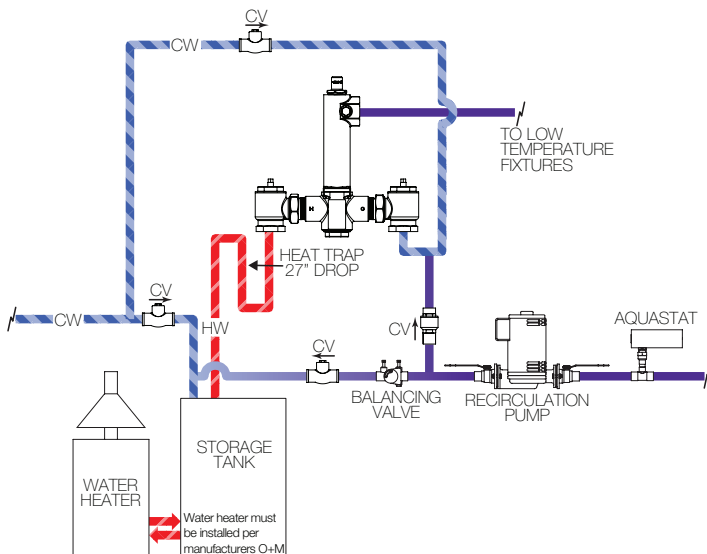

**Figure 2**

**When used in a dual temperature recirculating system**

